



Preface

Thank you for purchasing the FAB Intelligent Controls Series (FAB) products of our company. We recommend that you take some time to read this manual, before putting the FAB products in to service. The FAB has, amongst many features, the advantage being able to be operated off line to prove in service performance before being commissioned into service. When you read the manual you will find many more advantageous properties of the products, it will greatly simplify the operation of FAB for you.

FAB is a type of intelligent control, which uses function blocks for programming. Function blocks enable the control functions of a PLC to be achieved without the need for large number of instructions and complicated programming. When several function blocks are linked together in a specific way, relatively complicated control functions can be implemented. The programming can be carried out in a logical, speedy and verifiable manner. Programming can be implemented using a removable LCD liquid crystal display panel or by use of a computer. The latter approach is recommended for more complicated control schemes.

FAB has a very wide range of applications. It can be used for the automation of an extensive range of electrical and mechanical equipment. Flow control, building automation and many other fields. The implementation of FAB provides for automation of very many aspects of day-to-day life from home through to the commercial, manufacturing, mining, utility and service sectors of the economy. This manual will describe in detail the functional characteristics and operating methods for FAB, its' ancillary components and associated Quick II and FAB Scada operating software.

Notes:

Copyright of this manual and patent of FAB Intelligent Controls Series are the property of ARRAY ELECTRONIC CO., LTD. No reproduction or duplication of all or part of the contents of this manual is permitted without written consent in advance.

Our company reserves the right to make changes in design for improvement FAB Intelligent Controls Series without notification.

Any comments directed towards the improvement in the quality of this manual will be appreciated.



Preface

PAGE & CONTENTS INDEX

FAB HARDWARE.....	PAGES 1~104
QuickII SOFTWARE.....	PAGES 105~159
FAB-SCADA SOFTWARE.....	PAGES 160~216



FAB HARDWARE

A. IMPORTANT APPLICATION NOTES.....2
B. SAFETY GUIDE.....3

Chapter I Brief Introduction to FAB

1.1 Structure of FAB.....4
1.2 Specifications and models.....5
1.3 Features of FAB.....6

Chapter II Installation and connections of FAB

2.1 Installation.....10
 2.1.1. Installation methods.....10
 2.1.2 Dimensions.....11
2.2 Wiring of FAB.....12
 2.2.1 Connection of power supply.....12
 2.2.2 Connecting FAB inputs.....12
 2.2.3 Connecting FAB outputs.....14
 2.2.4 Connecting FAB network.....16

Chapter III General Description of Function Blocks

3.1 General function block (GF).....17
 3.1.1 AND.....18
 3.1.2 OR19
 3.1.3 NOT.....19
 3.1.4 NAND.....20



3.1.5 NOR.....	21
3.1.6 XOR.....	21
3.2 Special function blocks (SF).....	22
3.2.1 DPR.....	24
3.2.2 DDR.....	25
3.2.3 PLR.....	26
3.2.4 CW.....	27
3.2.5 RS.....	33
3.2.6 CPG.....	34
3.2.7 RPR.....	35
3.2.8 UCN.....	37
3.2.9 DCN.....	38
3.2.10 MPLR.....	38
3.2.11 TEL FAB.....	39
3.2.12 PLAY.....	41
3.2.13 MR.....	42
3.2.14 COMP.....	43

Chapter IV Programming operation on FAB panel

4.1 Display status of FAB.....	46
4.2 Confirm password	46
4.3 Function	47
4.3.1 Editor	48
4.3.1.1 Edit PRG	48
4.3.1.2 Insert FB.....	55



4.3.1.3 Delete FB.....56

4.3.1.4 Clear Prg.....57

4.3.2 FAB/Rom57

4.3.2.1 Read program from FAB(Rom→FAB).....58

4.3.3 SET.....58

4.4 Edit FAB function program.....59

4.4.1 Programming rules.....59

4.4.2 Middle relay.....60

4.4.3 Edit program.....61

Chapter V Remote programming and monitoring

5.1 Remote programming and monitoring via a MODEM.....72

5.2 Two connection methods for FAB remote programming and monitoring.....73

5.2.1 Connect MODEM by means of AF-C232 and AF-M232.....73

5.2.2 Connect MODEM by means of AF-MUL.....73

Chapter VI Voice Module

6.1 The structure of the voice module:.....75

6.2 Connection of AF-MUL and FAB.....76

6.3 Guide for using the voice multifunction block.....76

6.4 Recording.....79

6.5 Sound broadcasting.....81

6.6 Telephone remote control function.....81



6.7 Automatically dial function.....82
6.8 Example for using the voice module for control and security.....82

Chapter VII Technical specifications

7.1 General technical specifications.....85
7.2 AF-10MR-A / AF-20MR-A.....86
7.3 AF-10MT-D / AF-20MT-D.....87
7.4 AF-10MR-D / AF-20MR-D.....88
7.5 Telephone number receiving , transmitting and voice blocks.....89

Chapter VIII Application

8.1 Bell control of schools or factories.....91
8.2 The illumination of multifunction switch in stairs, halls etc.....93
8.3 Automatic gate control requirements.....94
8.4 Ventilation system.....95
8.5 Control requirements for neon lamp control system.....96
8.6 Illumination system for display windows.....98
8.7 Application of FAB in building management.....99
8.8 Application of FAB in a voltage diode counting
and packing assembly line.....101

Chapter VIII Quality Guarantee

Quality guarantee, warranty period and warranty range.....103



QUICKII: PROGRAMMING SOFTWARE OF FAB

Chapter I Brief Introduction to QUICKII

1.1 Operating interface.....107

1.2 Two types of editing windows.....108

 1.2.1 FAB logical diagram editing window.....108

 1.2.2 Simulation window.....109

1.3 Main functions.....110

 1.3.1 Editing function.....110

 1.3.2 Simulation operation function.....111

 1.3.3 Real-time monitoring.....111

 1.3.4 Communication with FAB.....111

 1.3.4.1 Local FAB communication.....111

 1.3.4.2 Remote FAB communication.....111

Chapter II Installation and uninstallation

2.1 Installation of Quick II.....112

2.2 Uninstallation117

Chapter III Operation Instructions and Block Library

3.1 Function Instructions.....119

 3.1.1 File.....119

 3.1.2 Controller.....120

 3.1.3 Communication.....120

 3.1.4 Display.....121



3.1.5 Options:.....	122
3.1.6 Help:.....	122
3.1.7 Edit:.....	123
3.1.8 Search:.....	124
3.1.9 Image Library:.....	124
3.1.10 FAB operation.....	125
3.1.11 Windows.....	125
3.2 Tool Bar.....	126
3.2.1 Standard Tool Bar.....	126
3.2.2 Control Tool Bar.....	127
3.2.3 Draw Tool Bar for Field Simulation Graph.....	127
3.3 Block Library.....	128
3.3.1 Block Library Operation.....	128
3.3.2 Block classification.....	129
3.3.3 Setup of block property.....	129
3.3.3.1 General Property.....	129
3.3.3.2 Setup of Special Property	130

Chapter IV Basic operations

4.1 Open File.....	140
4.1.1 Open a new file.....	140
4.1.2 Open an existing file	142
4.2 Edit Function Diagram Program.....	143

Contents



4.2.1 Place block.....	143
4.2.2 Edit block properties.....	146
4.2.3 Link.....	148
4.2.4 Move the link or block:.....	151
4.2.5 Delete block or link.....	151
4.2.6 Simulation operation	151
4.2.7 Save and Print	152
4.2.8 Write/Read:	154
4.3 Plot Field Simulation Graph.....	157
4.3.1 Plot with Draw Icons:.....	157
4.3.2 Insert Graph File directly.....	158



FAB-SCADA SOFTWARE

Chapter 1 Introduction to FAB-SCADA System

1.1 General Introduction.....161

1.2 Network Structure of FAB.....161

 1.2.1 Network of RS485 Buses.....162

 1.2.2 Network System for Remote Control via a Modem.....162

1.3 More detailed Introduction to the FAB-Scada System.....163

Chapter 2 Installation of FAB-Scada System

Chapter 3 Operation Instructions and Quick icons

3.1 Instructions and Icons in the Control Interface.....168

 3.1.1 System (Operation Instructions for System Management).....168

 3.1.2 Monitor (Operation Instructions for Monitor Setup).....168

 3.1.3 User (Users Management Instructions).....169

 3.1.4 Query (Query Instructions of the System).....169

 3.1.5 Report.....170

 3.1.6 Tools.....170

 3.1.7 Help.....170

3.2 Operation Instructions and Quick icons

 in the Drawing Interface.....171

 3.2.1 File (Files management).....171

 3.2.2 Edit.....171

 3.2.3 Tools.....172

 3.2.4 Help.....172



Chapter 4 Build a Supervisory Control System

4.1 Station design.....173

4.2 Add/Delete FAB.....175

4.3 Define the FAB I/O Port.....177

4.4 Drawing Monitoring Interface.....183

 4.4.1 Operation Instruments In Drawing Interface.....183

 4.4.2 Drawing Tools.....184

 4.4.3 Drawing the Monitoring Diagram.....186

 4.4.3.1 Page Setting.....186

 4.4.3.2 Draw the Monitor Diagram.....187

 4.4.3.3 Analyse the Communicating State.....196

Chapter 5 User Management

5.1 Modify Manager Name.....197

5.2 User Management.....197

 5.2.1 Append.....198

 5.2.2 Delete.....198

 5.2.3 Modify the Password.....198

 5.2.4 Query the User Information.....199

5.3 User Login.....199

5.4 User Logout.....200

5.5 Explanations for User Authorities.....200

Chapter 6 System Configuration

6.1 Set FAB Time.....201

6.2 Print.....201

6.3 Deploy.....202



Chapter 7 Data Query

7.1 Data Query.....	204
7.2 Back-up the Data Base.....	206

Chapter 8 Report

8.1 Create a Report.....	208
8.2 Browse.....	213



FAB HARDWARE

FAB Intelligent Control



A.

IMPORTANT APPLICATION NOTES:

1. The AF-C232 and LCD board, when a FAB is powered, must not be plugged in or disconnected.
2. The default password for FAB is 0001.
3. The default address for FAB is 000.
4. When programming a FAB using the LCD panel, the output of two function blocks must not be connected to one point, except for the CW function block.

For example:

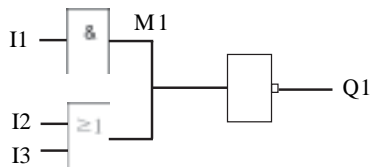

The above way is wrong, and the correct way is as follows:

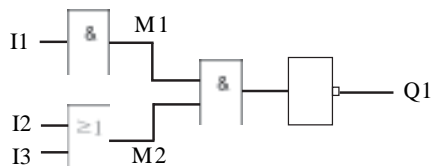



B.

SAFETY GUIDE:

This manual contains the precautions necessary for ensure your personal safety as well as for protection of the products and the connected equipment. These precautions are highlighted with a triangle WARNING symbol in this manual and are marked according to the danger levels as following:



Danger

It indicates that if appropriate precautions are not taken, serious incidents of personal injury or death, significant damage and loss of property will be caused.



Caution

It indicates that if appropriate precautions are not taken, incidents of personal injury, damage or some loss of property will be caused.



Note

Indicates that particular attention is required to all published information related to the use or disposal of products. Also in specific parts of documentation



Warning

Only suitably qualified personnel are allowed to operate and debug the products. Qualified personnel are specified as those persons who carry out commissioning, grounding and apply the appropriate identification to the circuits, equipment and systems according to the available safety practices and standards.



Note

Only when this product is transported and stored with care, then assembled, installed, operated and maintained in accordance with the documentation, can it carry out its' designed functions properly and reliably.



Chapter I Brief Introduction to FAB

FAB intelligent controller is a new type of programmable controller. It is programmed by the use of a Function Block Diagram. The programming of FAB is simpler and easier to learn than the programming of a conventional PLC, that uses ladder diagrams and associated instructions. The design concept, for the FAB series of products, includes a removable LCD panel. The program can be written directly into the FAB using this LCD panel. After programming the LCD panel can be retained or removed and replaced with a cover. The cost to the user can be reduced by multiple use of the LCD panel. The use of a computer is recommended for more complex control schemes.

Products within the FAB series are very compact and light in weight. FAB intelligent controls series can be used for both local and remote control, communication, networking and monitoring. FAB series can realize telephone-control, voice alarm and information, automatic dialing using the associated AF-MUL unit. FAB is widely used in many fields of industry, commerce, mining, agriculture, home automation etc.

1.1 Structure of FAB

AF-10 FAB series

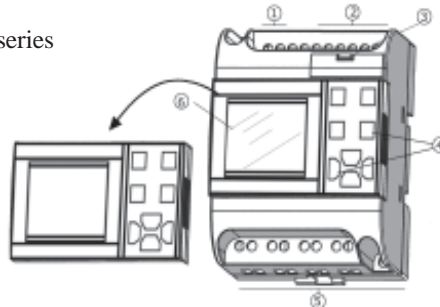

1. Terminals for AC or DC power as required by the selected FAB
2. Input terminals
3. Communication interface
4. Operating keys
5. Output terminals (Relay or transistor)
6. LCD display panel

Chapter I Brief Introduction to FAB

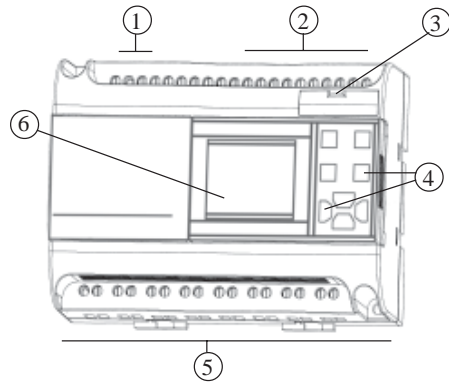

AF-20 FAB series

1. Terminals for AC or DC power, as required by the selected FAB
2. Input terminals
3. Communication interface
4. Operating keys
5. Output terminals (Output of relays or transistors)
6. LCD display panel

1.2 Specifications and models

Type No	Power	Input	Output
AF-10MR-A	AC 100V-240V	6 points AC digital input	4 points relay output
AF-10MR-E	AC/DC 12-24V	6 points AC/DC digital input	4 points relay output
AF-10MT-E	DC 12-24V	6 points AC/DC digital input	4 points transistor output
AF-10MR-D	DC 12-24V	6 points DC analog input	4 points relay output
AF-10MT-D	DC 12-24V	6 points DC analog input	4 points transistor output
AF-20MR-A	AC 100V-240V	12 points AC digital input	8 points relay output
AF-20MR-E	AC/DC 12-24V	12 points AC/DC digital input	8 points relay output

FAB Intelligent Control



Type No	Power	Input	Output
AF-20MT-E	DC 12/24V	12 points AC/DC digital input	8 points transistor output
AF-20MR-D	DC 12-24V	12 points DC analog input	8 points relay output
AF-20MT-D	AC/DC 12-24V	12 points DC analog input	8 points transistor output
AF-LCD	FAB removable LCD panel.		
AF-C232	Interface between AF-M232 and FAB		
AF-C485	Interface between FAB and RS485 bus		
AF-P485	Interface between computer and RS485 bus.		
AF-M232	Adapter between MODEM and AF-MUL or AF-C232		
AF-MUL	Voice alarm, telephone control and dial automation.		
AF-MUL-D	DC type voice module		
QUICK II	FAB programming software		
FAB-Scada	SCADA software		

1.3 Features of FAB

1. Removable programming panel with Liquid Crystal Display

There is an operating panel with LCD display on the front side of FAB. You can use the operating keys on this panel to edit directly the control program for FAB. Moreover, this LCD display panel is removable, and it can be set up according to your needs. When needed it can be plugged in. When not needed it can be removed and replaced with a front cover,

Caution



The LCD display panel shall be plugged in or removed only after AC or DC power has been turned off.

Chapter I Brief Introduction to FAB



2. Well featured and compact design

If you are thinking of improving the application of your equipment, FAB provides very many features. FAB is very compact, 90mm x 71mm x 58mm (AF-10 Series) and 90mm x 126mm x 58mm(AF-20 Series)

3. With the function blocks used for programming, the program storage capacity of FAB is large. The control functions of FAB can be implemented only with function blocks incorporated into a function block diagram. The same level of control implemented by a conventional PLC would require a much larger and more detailed program. When several function blocks are linked together in a specific way, then relatively complicated control functions can be implemented. FAB has a storage capacity of programs for up to 127 function blocks, there is a large application resource to satisfy the requirements for complicated control. A program, when downloaded into FAB will never be lost as FAB does not rely on a battery for the memory function.

4. QUICK II: programming software.

The control program can be downloaded directly, with the use of the LCD panel, into a FAB unit. With more complicated control schemes the use of an ancillary computer, loaded with QUICK II software, is recommended. The control program can then be written into the memory of the FAB. QUICK II is a very friendly human-machine interface programming software. It can edit the function diagrams and also can analogously run the written program. It provides an off-line testing function to the user. This feature overcomes much of the possible inconveniences normally experienced with on-line testing and commissioning. The system can be proven before being put into actual service. QUICK II will not only guide you to implement the editing of the control programs, but will also perform the real-time monitoring for the field environment and the operational conditions of FAB.

5. Real-time clock function

FAB intelligent controls Series have an instant real-time recording function. FAB can execute the operations according to the planned schedule. Up to 127 different time intervals can be set, it is very suitable for systems which require time control.

6. Analog input and transmission

In addition to receiving a switching input, FAB can also receive the

FAB Intelligent Control



analog input to implement the control of temperature, humidity, pressure, flow, level unit, etc., and transmit them remotely to a computer for monitoring.

7. To implement the remote programming and the supervision and control of data acquisition through MODEM.

When you need to implement programming, write and modify programs for FAB controls from a remote location it is necessary to connect FAB to MODEM through a touch telephone. With this connection it is possible to perform data acquisition and real-time supervision and control from a remote location.

8. Security cipher code function

FAB is provided with protection for the programs downloaded into it. A security cipher code can be set before programs are written. The programs can then only be modified after the correct cipher code is entered.

9. Telephone function

FAB is equipped with telephone and voice function blocks. It is possible to dial directly through a telephone line after the required telephone number has been preset. FAB can be dialed automatically, when the conditions are satisfied so as to implement advice or alarm functions. Moreover, FAB can also receive remote signals transmitted through a telephone line in order to control the terminal equipment.

Note:

It is necessary to configure AF-MUL multifunctional voice block for the implementation of telephone function and voice function.

10. Voice function

FAB can provide voice recording and broadcasting back functions for the automatic control industry, creating intelligent controls which can give audible voice outputs, both locally and through remote speakers.

11. Networking function

FAB has a networking function. It can link up to 255 FABs to make up a network to implement the instant supervision and control from a common computer.

Chapter I Brief Introduction to FAB



12. FAB-Scada monitoring and control functions.

FAB Scada software provides for the monitoring and control functions of a group of FABs

13. Middle relay feature.

With the addition of the middle relay more complicated control schemes can be developed.

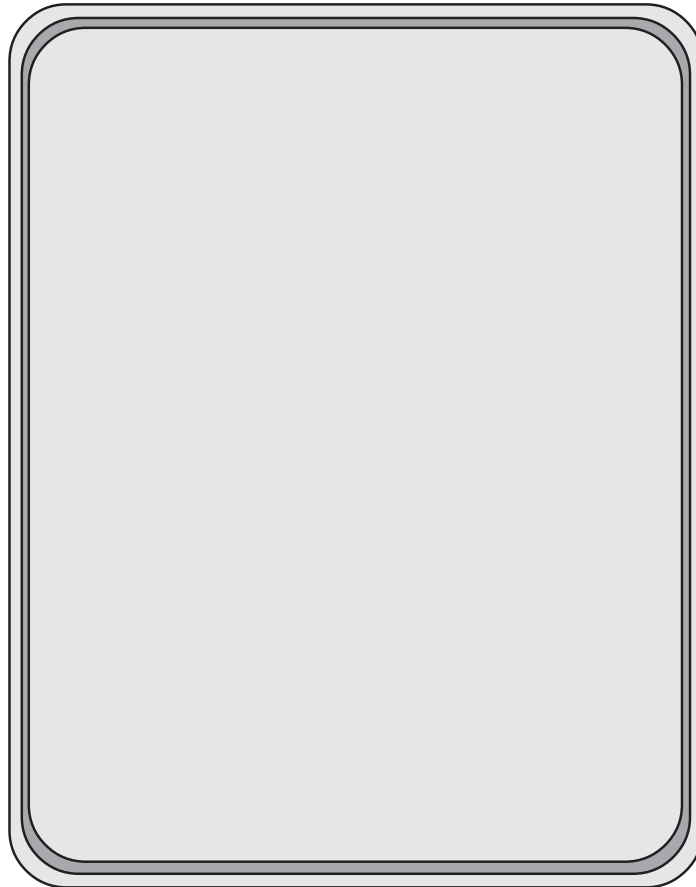



Chapter II Installation and wiring of FAB

2.1 Installation

2.1.1. Installation method

FAB is small and it is suitable for fitting inside panels or machinery within its' specification criteria. The installation of FAB is quite simple:

1. Use a standard DIN rail for installation of FAB as shown in Fig. 2.1.
2. Use the two diagonal clearance holes on FAB for direct mounting.

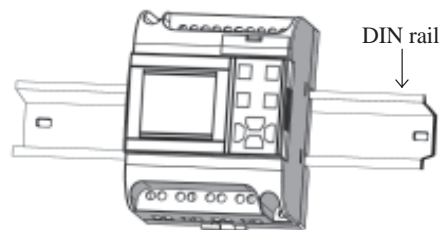

Fig. 2.1 Use standard DIN rail for installation of FAB

The LCD panel of FAB is readily removed by partially withdrawing it from the FAB, as illustrated, using a spade tipped screwdriver. The LCD panel can then be readily fully withdrawn manually.



Caution:

Do not remove the LCD panel whilst the FAB is powered, otherwise the FAB and LCD panel may be damaged and endanger the personal safety of the user.



Fig. 2.1 Remove LCD panel as instructed



2.1.2 Dimensions

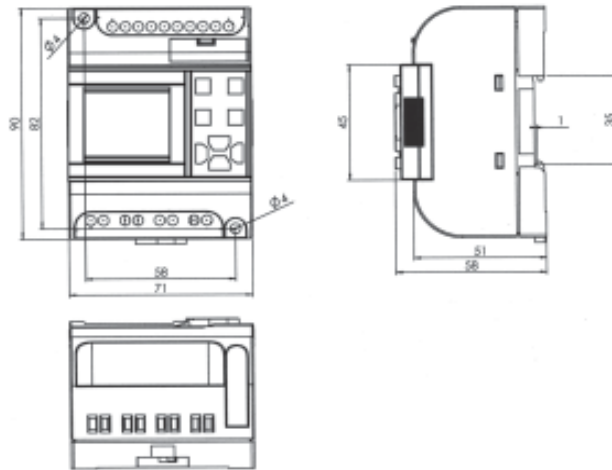

Fig 2.3 AF-10 FAB Series installation dimensions (Unit: mm)

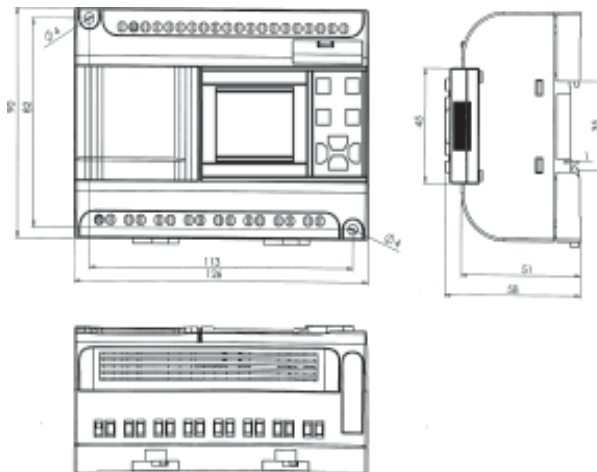

Fig 2.3 AF-20 FAB Series installation dimensions (Unit: mm)



2.2 Wiring of FAB

A screwdriver with a spade tip width of 3mm is used for the wiring of FABs. The maximum cross sections of the wires that can be inserted into the terminals are determined according to the following sizes:

- 1 x 2.5mm²
- 2 x 1.5mm²

2.2.1 Connection of power supply

- 1 For AF-10MR-A and AF-20MR-A FABs, the rated power supply requirement is 100-240VAC, 50/60HZ.
2. For AF-10MT-E, AF-10MR-D, AF-10MT-D, AF-20MT-E, AF-20MR-D, AF-20MT-D) FABs, the rated power supply requirement is 12-24V DC
3. For AF-10MR-E and AF-20MR-E the rated power supply requirements are 12-24V AC or 12-24V DC.

The power connection for FABs is as shown in the following drawings:

2.2.2 Connecting FAB inputs



Fig 2.5 AC Type



Fig 2.6 DC and AC/DC Type

The input to FAB can be either digital, such as on/off switches etc., or analog, such as pressure, temperature, humidity, flow, etc. The specific requirements are as follows:

Chapter II Installation and wiring of FAB



Type Demand	AF-10MR-A AF-20MR-A	AF-10MR-D AF-10MT-E AF-10MT-D AF-20MR-D AF-20MT-E AF-20MT-D	AF-10MR-E AF-20MR-E
Switch status 0	<40VAC	<5VDC	<5VDC
Input current	<0.24mA	<1.5mA	<1.5mA
Switch status 1	>=80VAC	>=10VDC	>=10VDC
Input current	Typical 0.24mA	Typical 3mA	Typical 3mA
Proximity switch type with direct input	2lines 3lines 4lines	2lines 3lines 4lines	2lines 3lines 4lines
Switch with glow lamp	When the close current of a glow lamp is less than or equal to 0.2mA, it can be connected directly, and when the close current of a glow lamp is greater than 0.2mA, the glow lamp should be connected through a relay or an additional N-type drive.	/	/
		I1~I6/I1~Ic receivable analog value	/

Note: For AF-10MR-D, AF-10MT-D, AF-20MR-D and AF-20MT-D that can receive analog input, analog can be input through all input interfaces (I1-I6 or I1-Ic). They can be set to analog input or digital input as either may be used in the program. They will be recognized as analog inputs when the input terminal is connected with an AN function block, and they will be recognized as digital inputs when the input terminal is not connected with an AN function block. You need to set analog inputs first when you use FAB-Scada software for supervision.

The analog inputs require 0V ~ +10V voltage signals. These are divided equally in 0.1V increments. In programming, all the block parameters related to the analog inputs are based on the minimum increment of 0.1V. They can be recognized as digital input when the input voltage is more than 10.0V and cannot be recognised as an analog input.

For the digital input off, when the switch status changes from 0 to 1, the time of Status 1 must be greater than 50ms, and when the switch status changes from 1 to 0, the time of Status 0 also must be greater than 50ms.



Connecting FAB is shown as in the following figure:

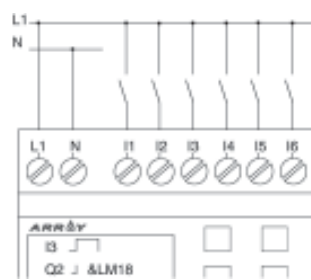

Fig 2.7 AC Type

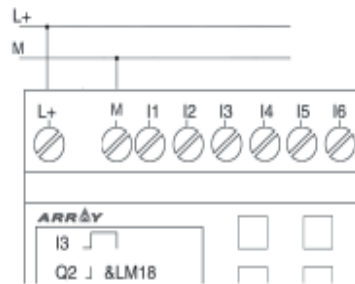

Fig 2.8 DC Type (E Type)

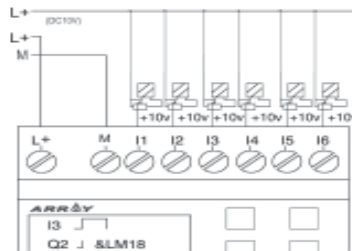

Fig 2.9 DC Type (D Type)

2.2.3 Connecting FAB outputs

For AF-10MR-A/AF-20MR-A/AF-10MR-D/AF-20MR-D AF-10MR-E /AF-20MR-E /AF-10MR-F/AF-20MR-F FAB series, the output are relays. The contacts of relays are insulated from the power supply and input.

For AF-10MT-E/AF-20MT-E and AF-10MT-D/AF-20MT-D FAB Series, the output are of transistor type, provided with short circuit and overload protection. It is necessary to have a separate power supply for their loads.



1. Requirement for the relay output

Various loads such as lamp, fluorescent tube, motor, contactor, etc., can be connected to the outputs of FABs. The max. ON output current that can be supplied by FAB, is 10A for the resistance load and 2A for the inductive load. The connection is in accordance with the following figure 2.10:

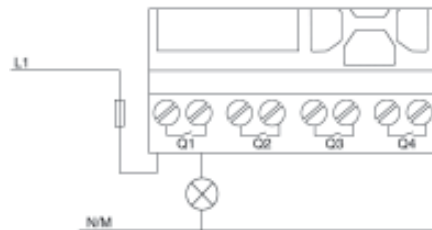

Fig 2.10 Relay Output

2. Requirement for the electronic transistor output

The load connected to FAB must have the following characteristics:
The maximum switch current cannot exceed 2A
when the switch is ON (Q=1), the maximum current is 2A.
The connection is in accordance with the following figure 2.1:

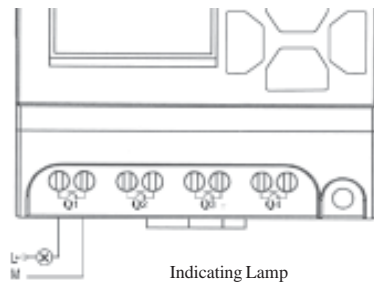

Fig. 2.1 Transistor Output



Note: M line should be connected to M of FAB Power supply, and the load should be directly connected the L+ 1, and the load current should be DC .



2.2.4 Connecting FAB network

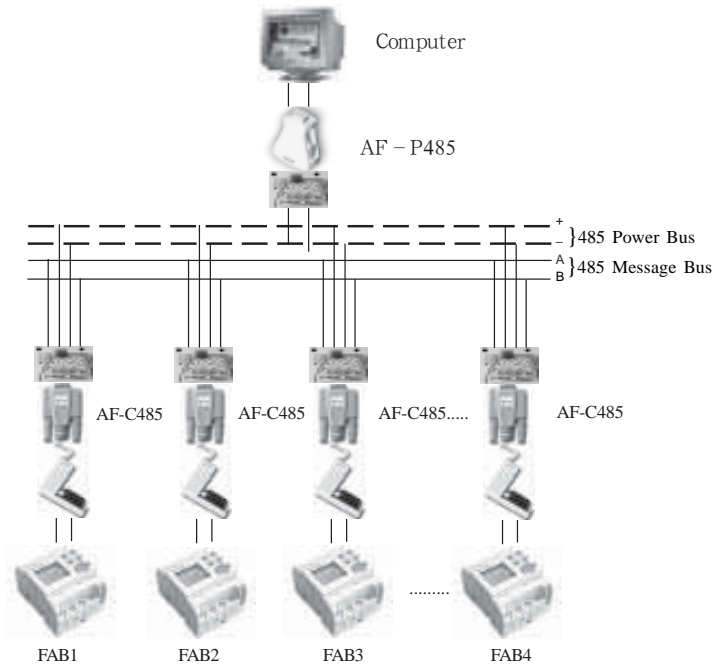

Fig. 2.12 Connecting method



Note:

One PC can be connected with up to 255 FABs. Please set addresses respectively for each FAB. The address range is 000~254.





Chapter III General Description of Function Blocks

FAB series adopts the programming method with the use of function blocks. 20 function blocks are configured in total, and each block can achieve a specific control function independently, e.g. time-delay ON, time-delay OFF, setting switch time, counter function, etc. As several blocks are linked up in a specific way relatively complicated control functions can be realised. Programming with function blocks is simpler and better appreciated than the conventional PLC instruction programming.

The following types of operator for FAB function blocks are available for options:

1. Options of input port: I1 - IC (Input port), Q1- Q8 (Output port), Moo-M126 (middle relay), HI (High potential status), LO (Low potential status), X (no input connection), P0 - P9 (Telephone two-tone pulse)
2. Options for output port: Q1 ~ Q8 (output port), Moo~M126 (intermediate relay).

3.1 General function block (GF)

There are 6 general function blocks in total as listed in the following table:

Table 1: General function blocks

Line diagram	FAB function block	Function
Series Connection of NO contacts		AND
Parallel connection of NO contacts		OR
Phase inverter		NOT



Dual commutator contact		XOR
Parallel connection of NC contacts		NAND
Serial connection of NC contacts		NOR

3.1.1 AND

Serial connection of a certain number of NO contacts is shown in the line diagram as follow:

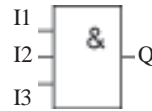
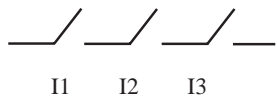

The symbol of AND is as shown in the follows:

This function block is called as AND, because only when all of I1, I2 and I3 are all in status 1, the status of Output Q will be 1 (i.e. the output is closed).
Logical frame of AND.

I1	I2	I3	Q
0	0	0	0
0	0	1	0
0	1	0	0
0	1	1	0
1	0	0	0
1	0	1	0
1	1	0	0
1	1	1	1



3.1.2 OR

Parallel connection of a certain number of NO contacts, is shown in the electrical line diagram as follows:

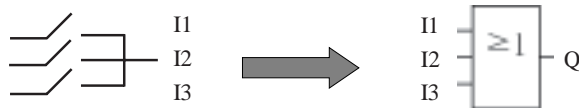

This function block is called as OR, because the status for at least one of inputs I1 or I2 or I3 is 1 (i.e. close), then output Q is 1.

Logical frame of OR”:

I1	I2	I3	Q
0	0	0	0
0	0	1	1
0	1	0	1
0	1	1	1
1	0	0	1
1	0	1	1
1	1	0	1
1	1	1	1

3.1.3 NOT

This function block is called NOT, because the input status is 0, Output Q is 1, and vice versa. In other words, NOT is the phase inverter for the input point.

The phase inverter is indicated in the line diagram as follows:

The phase inverter is called as NOT in FAB, its symbol is as follows:





Logical frame of NOT:

I1	Q
0	1
1	0

3.1.4 NAND

Parallel connection of certain number of NC contacts, which is shown in the electrical line diagram as follows:

The symbol of NAND in FAB is shown as follows:

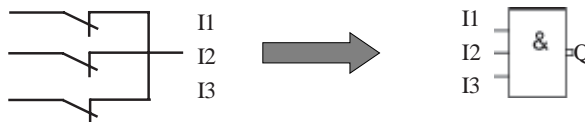

This function block is called NAND, because only when all I1, I2 and I3 are all in status 1 (i.e. close), its Output Q is in status 0.

Logical frame of AND”:

I1	I2	I3	Q
0	0	0	1
0	0	1	1
0	1	0	1
0	1	1	1
1	0	0	1
1	0	1	1
1	1	0	1
1	1	1	0



3.1.5 NOR

Parallel connection of a certain number of NC contacts, which is shown in the line diagram as follows:

The symbol of NOR in FAB is shown as follows:

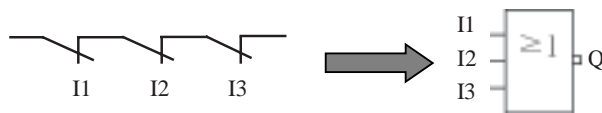

Only when all the input of NOR function blocks are at a low potential (status 0), the output will be closed (status 1). If any input is at high potential (status 1), the output will be open (status 0).

Logical frame of NOR:

I1	I2	I3	Q
0	0	0	1
0	0	1	0
0	1	0	0
0	1	1	0
1	0	0	0
1	0	1	0
1	1	0	0
1	1	1	0

3.1.6 XOR

As shown in the line diagram, the two commutator contacts for XOR are connected in serial as follows:

In FAB, the symbol of XOR is shown as follows:

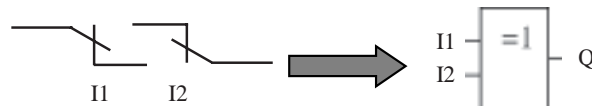



When the status of input are not the same, the output status of XOR is 1.

When the status of input are the same, the output status of XOR is 0.

Logical frame of XOR.







I1	I2	Q
0	0	0
0	1	1
1	0	1
1	1	0

3.2 Special function blocks (SF)

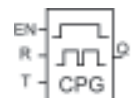
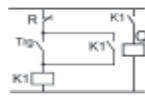
Function	Representation	Graphic
DPR (ON time delay)		
DDR (OFF time delay)		
PLR (Pulse relay)		
CW (Clock switch)		
RS (RS relay)		

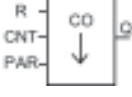
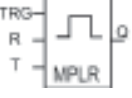
**Chapter III General Description of
Function Blocks**



CPG (Clock pulse generator)		
RPR (Hold ON time-delay relay)		
UCN (Up-counter)		
DCN (Down-counter)		
MPLR (Single pulse time relay)		
TEL (Telephone dialing block)		
AN (analog input block)		
PLAY(Broadcast voice section & Selector switch blocks)		
MR (Recording voice section& Selector switch)		



3.2.1 DPR

Line diagram/Symbol in FAB	Pin	Description
	input TRG	After TRG is triggered, the time delay timer starts timing. (If TRG stops triggering during the timing of timer, the timer will terminate the timing).
	Parameter T	After time T, the output is on (the output signal changes from 0 to 1).
	Output Q	If there is still trigger signal, when time T is up, the output will be on.

Time Sequence Frame:

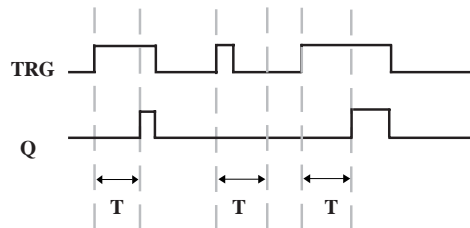

Description:

When the status of TRG input changes from 0 to 1, the time-delay timer starts timing. If Input TRG holds status 1 for a sufficiently long time, the output will be changed to 1 after the time T has elapsed. There is a time delay between the input turning ON and the output turning On, that is why the ON time-delay is so called.

When the input TRG is Status 0, the output will reset to status 0.

This function is applicable to override vibrations of switches, delayed start-up of motor, delayed turning-on of lights, etc.

The assignment range for T is 0.01- 99.99, and the time units can be set respectively to hour (H), minute (M) and second (S). Its time accurately can reach 0.5/00 S.



3.2.2 DDR

Line diagram/Symbol in FAB	Pin	Description
	Input TRG	Turn on the time of the time-delay off relay ,when the input TRG (trigger) is at the descending edge (changing from 1 to 0)
	Input R	The timer of disconnecting time-delay relay is reset via R (Reset Input), and Output Q is set to 0. (R has higher priority to TRG).
	Parameter T	The output is disconnected (the Q status is changed from 1 to 0) when the time T elapses .
	Output Q	Input TRG is activated then the output is turned on (Q=1) and is kept ON until it is reset when the set time T is up.

Time Sequence Frame:

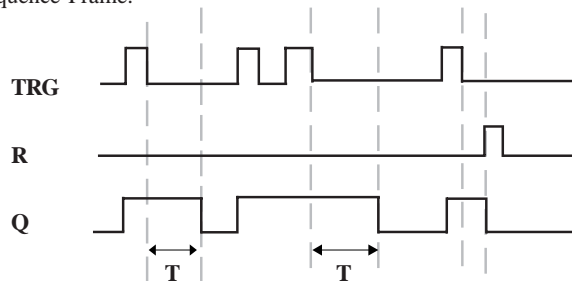

Description :

When Input TRG is Status 1, Output Q is changed at once to Status 1. When Input TRG is changed from 1 to 0 (when the descending edge comes), the internal time delay timer of FAB is activated and Output Q is still remained in Status 1. When the set time T is up, Output Q becomes 0 and the timer is reset 1 . If Input TRG changes from Status 1 to Status 0 again, the timer is activated again. Before the set time T is up, the timer and output can be reset via R (Reset) input.

FAB Intelligent Control



This function is applicable to the lighting of staircase, the control of barriers in a car park, the control of a water throttling valve, etc.

The assignment range of T is 0.01 ~ 99.99, and the time units can be set respectively to hour (H), minute (M) and second (S). Its time accuracy can reach 0.5% S.

3.2.3 PLR

Line diagram/Symbol in FAB	Pin	Description
	Input TRG	Trigger input (TRG) makes the output On and Off
	Input R	The output Q is reset via R (Reset input) (Q=0, R has a higher priority to TRG).
	Output Q	Every time TRG changes from 0 to 1, the status of Q will be changed (i.e. from Status 0 to Status 1 or vice versa).

Time Sequence Frame:

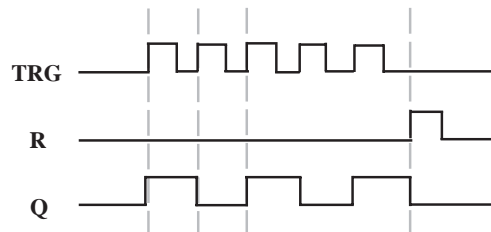

Description :

Every time the trigger input TRG changes from status 0 to Status 1, the status of Output Q will change accordingly (The status of Q will be reversed).

Reset Q to Status 0 via Input R.

After the power is ON or OFF, the pulse relay is reset and Output Q changes to 0.

Chapter III General Description of Function Blocks



This function can be applied to the lighting of corridors and staircases, and the start/stop of motor with a single push-button, etc.

3.2.4 CW

FAB has clock switches for 127 time intervals.

Live diagram/symbol	Pin	Description
	ON/OFF	Set the switch time of the output. Output switch time setting. ON (T1) is the time setting for output to begin turning on. OFF (T1) is the time setting for output to begin turning off.
	Parameter D/W	Options of date system of week system. D for the date system and W is for the week system.
	Output Q	If one of the parameterized time intervals is ON, the output is ON.

Notes regarding the time sw:

1. When the date system is selected for the timing of a time switch.

For the same output channel, up to 127 time switches can be set, and these switches must be put in order according to the time sequence, e.g.

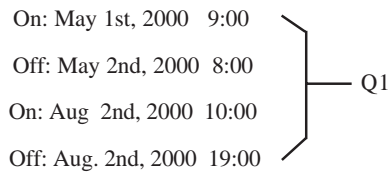

The above arrangement is correct, while the below arrangement is wrong:

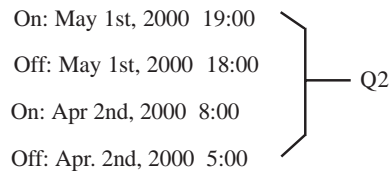

Chapter III General Description of Function Blocks



In the time setting for the time switches, if 2 time setting points for ON/OFF are set, the output is ON status only in this time interval, and the output keeps the original status when it is before the ON time, and the output is OFF status when it is after the OFF time.

It can directly be changed into the above logic from a computer and transmitted to FAB and is inaccessible to the user

3. If only ON time or OFF time is set, the changes of output status are as follows:

Setting condition	Time	Output status
only ON time	Below ON time	Keeping the original status
	Greater than and equal to ON time	ON status
only OFF time	Below OFF time	Keeping the original status
	Greater than and equal to OFF time	OFF status

4. When the week system is selected for the timing of time switches:

The interval from Monday to Sunday is defined as a circle (MO is the start point, and SU is the end point). In one time interval, it is not allowed to set the start point after the end point. It is OK to flow the Sequence of MO, TU, WE, TH, FR, SA, SU,

The following definition should be noted.

For example, ON : 5:00 every Sunday
 OFF: 8:00 every Monday

FAB Intelligent Control



It can be programmed by three blocks as follows:

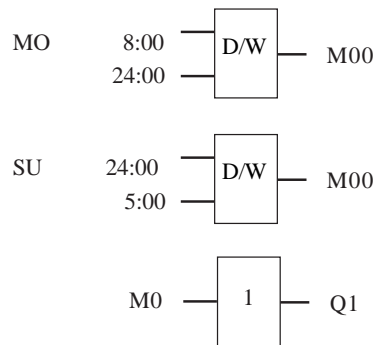

Notes:

MO : Monday

TU : Tuesday

WE : Wednesday

TH : Thursday

FR : Friday

SA : Saturday

SU : Sunday

MO-SU : every day from Monday to Sunday

MO-TH : every day from Monday to Thursday

MO-FR : every day from Monday to Friday

MO-SA : every day from Monday to Saturday

FR-SU : every day from Friday to Saturday

SA-SU : every day from Saturday to Sunday

As for the case that OFF time is set without ON time, e.g. it is set to be OFF at 5:00 from Monday to Thursday, and FAB can turn OFF the output after 5:00 everyday from MO ~ TH, as to when it is going to be ON, it depends on other factors (the original status will be maintained for Friday, Saturday and Sunday).

5. Whether the date system or the week system is selected, the time intervals for the time of the same date should be arranged in chronological order, for example:

Chapter III General Description of Function Blocks

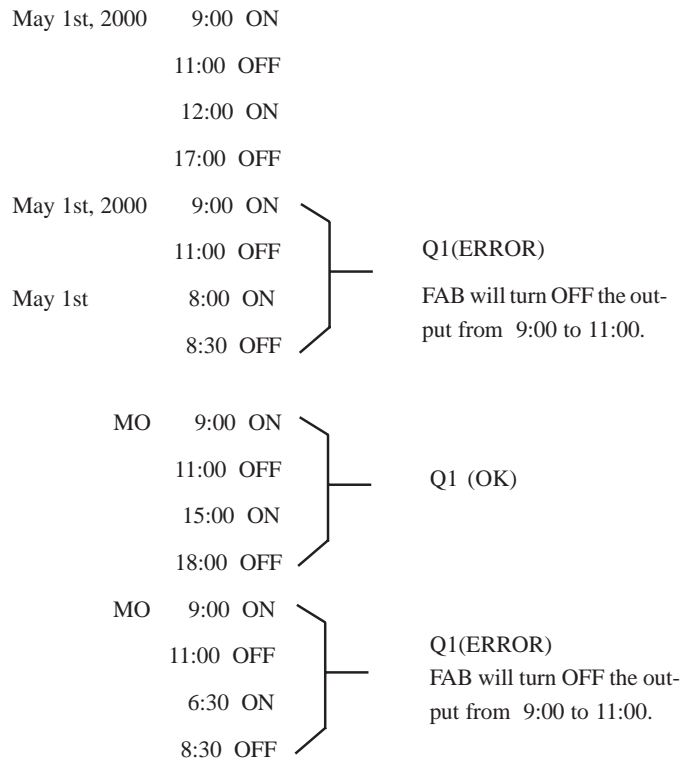

Note: this phenomenon follows the principle of the later command surpassing the former command.

FAB Intelligent Control



6. When the week system is selected, if ON is set at 8:00 and Off is set at 9:00 of MO~ TH, FR, SR and SU will maintain the former status the D selection will be neglected by FAB i.e., the original ON status will be kept as ON and the original OFF status will be kept as OFF.

7. When you program by using the LCD panel, having selected Week system, it is only necessary to set T1 and T2, and it is meaningless to set D . It is necessary to set D when you have selected Day system. D is the setting of data, T1 is the setting of ON time, and T2 is the setting of OFF time.

8. Clock hold circuit

For FAB, when there is a power failure or a power is cut off, the internal clock will continue to run. The time that FAB can maintain the internal clock to run depends on the temperature, when the temperature of the FAB is 25 degrees C, the clock can continue normal operation for more than 100 hours.

9. Conflict between time intervals

When using the time intervals to set the ON/OFF time for the clock, the clock switch will make the output ON at the ON time unless it has already been ON, and the clock switch will make the output OFF at the OFF time unless it has already been OFF.

10. Accuracy of RT clock

The accuracy of RT clock can reach 1s. A requirement with a duration less than one minute can be done by using one function block in FAB. This function is applicable to the control related to time, e.g. ringing bell for classes in school, work in factories, timed start-up and shutdown of machines, etc.



3.2.5 RS

Line diagram/Symbol in FAB	Pin	Description
	Input S	Set Output Q to 1 via Input S (Set). S port can receive two-tone signal input such as P0-P9 phone signals.
	Input R	Set Output Q to 0 via Input R (Reset). If S and R are 1 at the same time, the Output Q is 0 (with R having a priority to s).
	Output Q	When S is input, Q is ON and held ON, and will not be reset until Input R is set.

Switch characteristics

RS relay is a simple trigger. The output value depends on the input status and the original output status. The following list of true values is used to describe the logic relations:

S	R	Q	REMARK
0	0		Status remain to the original value
0	1	0	Reset
1	0	1	Set
1	1	0	Reset (having a priority to Set)



Note: P0-P9 represent the 0-9 buttons of the telephone. RS function block has the function to receive a two-tone signal. You can use the RS function block to receive telephone signal and control the external equipment.



3.2.6 CPG

Line diagram/ Symbol in FAB	Pin	Description
	Input EN	Make clock pulse generator ON and OFF via Input EN (Enable).
	Input R	Make Output Q be 0 via Input R (Reset).
	Parameter T	T is the time length of output to be ON and OFF.
	Output Q	Every time EN changes from 0 to 1, the internal timer begins to time, and when Time T is up, the output is 1. If EN is held on 1, timing can be started again, and when Time T is up again, the output is 0. The cycle operation is continued in this way until EN is 0 and Output Q is 0. When R is 1, then the output Q is 0. And when R changes from 1 to 0 and EN is 1, all the initial status of Q changing from 0 to 1 will start its cycling changed.

Time sequence frame is as follows:

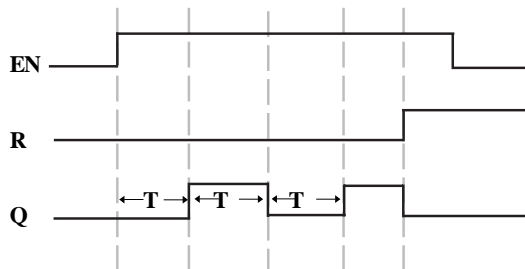

Chapter III General Description of Function Blocks



Notes:

Use Parameter *T* to set ON/OFF time. The assignment range of *T* is 0.01 ~ 99.99, and the time units can be set respectively to hour (*H*), minute (*M*) and second (*S*). The time accuracy can reach 0.5 Second.

Input *EN* (Enable) enables the clock pulse generator to work. Output *Q* of clock pulse generator will flip-flop the status every time the time *T* elapses, and cycle operation is continued in this way until Input *EN* (Enable) is 0. The clock pulse generator then stops operation and Output *Q* is 0.

This function is applicable to generated pulse automatically and to switch ON/OFF automatically.

3.2.7 RPR

Line diagram / Symbol in FAB	Pin	Description
 	Input TRG	Timer for ON time delay is started via Input TRG (Trigger).
	Input R	Timer for ON time delay is reset to ON via Input R, and make Output Q is 0 (The priority of R is higher than that of TRG).
	Parameter T	After TRG is triggered and the time T elapses, the output is ON.
	Output Q	After time delay T elapses, the output is ON.

FAB Intelligent Control



Time Sequence Frame:

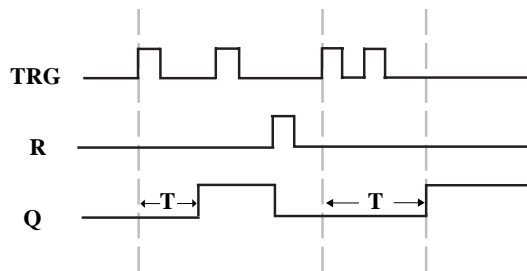

Notes:

If the status of Input TRG changes from 0 to 1, the internal timer will be activated. When time T is up, Output Q becomes 1 and then the input TRG coming again has no effect on output Q. Only when Input R becomes 1 again Output Q and Timer T will be reset to 0.

This function is applicable to the locations where the time-delay ON and hold ON status are required.

The assignment range for T is 0.01 - 99.99, and the time units can be set respectively to hour (H), minute (M) and second (S). Its time accuracy can reach

0.5 /00 second.



3.2.8 UCN

Line diagram/symbol in FAB	Pin	Description
	R	Input R has priority to other input, When it inputs resetting signal, the counter is reset to 0 and cut put Q is reset simultaneously
	Input CNT	When CNT counting is input, the counter only counts the leading edge triggering (the status changes from 0 to 1), i.e. every time the leading edge is triggering, the counter will increase by 1.
	Parameter PAR	When the internal counting value is greater or equal to Parameter PAR, Output Q is 1 The assignment of counter is 0 ~ 999999.
	Output Q	When the counting value has been reached, Output Q is On.

Time Sequence Frame:

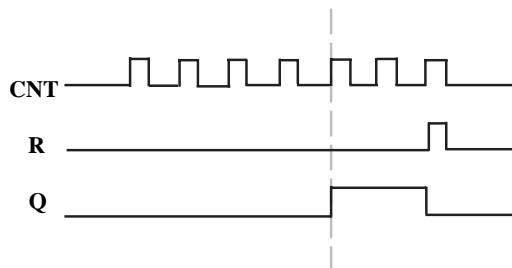

Note: This function is applicable to the locations where counting is required.



3.2.9 DCN

Line diagram/Symbol in FAB	Pin	Description
	Input R	R has a priority to other input, when R inputs reset signal, the counter is reset to 0 and output Q rests simultaneously.
	Input CNT	When CNT counting is input, the counter will only count the front edge triggering (the status changes from 0 to 1), i.e. every time the leading edge is triggering, the counter is decreased by 1.
	Parameter PAR	When the internal parameter is decreased to 0, Output Q is 1. The assignment of counter is 0 ~ 999999.
	Output Q	When the counting value is 0, Output Q is On.

Note: This function is applicable to the locations where the counting is required.

3.2.10 MPLR (Single-pulse time relay)

Line diagram/Symbol in FAB	Pin	Description
	Input TRG	Trigger the input to activate the single-pulse time relay. When the leading edge of TRG comes, a pulse with a duration of T is output.
	Input R	Reset the single-pulse time relay. When R is 1, Output Q becomes 0.
	Parameter T	The assignment of the pulse duration setting is 0.01 ~ 99.99 (second, minute, hour). The time accuracy can reach 0.5 second.
	Output Q	Every time TRG changes from 0 to 1, Q outputs a pulse with a duration of T.



Time Sequence Frame:

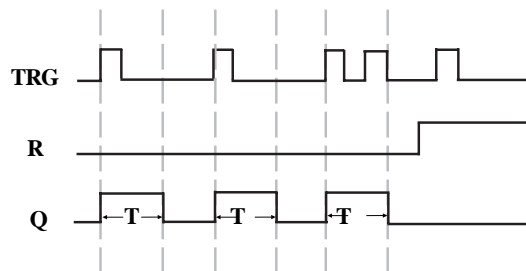

Notes:

When Q is 1, TRG pulse will have no effect on Output Q.

This function is applicable to the locations where the pulse duration is required to be increased.

3.2.11 Tel (The AF-MUL to be used in conjunction with FAB)

Figure	Pin	Description
	Input	The input port is selected as follows: I1 ~ IC, Q1 ~ Q8, HI, LO, M00 ~ M126, P0 ~ P9.
	Output	When output is 1, the telephone number of output port will be dialed to output. If the input has been 1 all the time, dialing will be kept on, once every 30 seconds and when the input is 0, dialing stops. The option range of output port will not exceed 25-digit telephone number.

FAB Intelligent Control



Note:

The function of telephone blocks are mainly dialing, output, alarm, etc. This block is used together with the locking-up relay (RS relay) function block. It can be used to not only receive the coming call signals to control the terminal equipment, but also dial to output the alarm under certain conditions. Presentation on how to implement it is made as follows:

a. The basic circuit for controlling periphery devices by incoming call is shown as the following diagram:



This control requires the presetting of the telephone two-tone signal (P0 ~ P9) to drive RS relay during the programming of FAB, the periphery devices is driven by the output of RS relay, so when FAB receives P0 ~ P9 signals of an incoming call, it is possible to control the peripheral devices.

Step 1: Use the external telephone to dial the telephone number of the telephones connected to FAB, connecting FAB then there appears the voice prompt: please enter the password.

Step 2: Enter the password of the FAB correctly, and there appears the voice prompt: please enter the information code.

Step 3: Dial P0 - P9 control signals to control the output of FAB. RS block input has telephone two-tone pulse signals P0 - P9, during programming, the input of RS needs to be set to P0 - P9, so as to implement the control function of the telephone function block.

When I1 is ON and I2 is OFF again, the second section can then be input. (It is called accumulated input).

This function should be applied to the locations where the voice prompt is required. It is necessary to first make a recording.

Chapter III General Description of Function Blocks



b. Telephone alarm: When the input signal of this function block is 1, start to dial automatically the preset number.

After the telephone lines and power supply lines of FAB and AF-MUL are connected, dial the number of the telephone that is connected with FAB. When you have got through, you will hear: please input password. Now input the password for programming through the telephone number keyboard and please do not forget to start with *. When the password has been properly input, please input * and 0, you will hear the prompt voice: electrical appliance is switched on. Relay Q1 will be on at the same time. If * and 9 are input, you will hear: electrical appliance is switched off. Relay Q1 will be off. The prompt voices for switch-on and switch-off will continue for 5 seconds.

This feature is used in locations where both automatic dialing and automatic alarm are required. FAB matched with AF-MUL, will achieve telephone control and voice function. Please refer to chapter 6 .

When you program the CW clock on the LCD panel, you should add : at the end of the telephone number, this marks of the end of the telephone number .

3.2.12 PLAY (The AF-MUL to be used in conjunction with FAB)

Figure of FAB	Pin	Description
	On	When ON is 1, Output Q is 1, i.e. the voice section is turned on for broadcasting. The options range for its input is I1 ~ IC, Q1 ~ Q8, HI, LO, M00~M126,X.
	OFF	When OFF is 1, Output Q is 0, i.e. the voice section is turned off. The option range of its input is I1 ~ I12, Q1 ~ Q8, HI, LO, M00~M126, X.
	Q	The option range of output is 04~ 98, and there are 98 voice sections in total.

This function is applied to the locations where the voice prompt is required

FAB Intelligent Control



3.2.13 MR (The AF-MUL to be used in conjunction with FAB)

Figure of FAB	Pin	Description
	ON	When ON is 1, record the voice sections. The option range of the input is I1 - IC, Q1 - Q8, HI, LO, M00~M126, X.
	OFF	When OFF is 1, recording is completed, turn off the switch for recording voice sections. The option range of this input is I1 ~ IC, Q1 ~ Q8, HI, LO, M00~M126, X.
	Q	The options for the output port are 01 ~ 09. Please note that: when the output is selected as 99, it does not represent to record the 99th voice section but that to clear all the voice sections, therefore, care should be taken for using .



Notes:

Please refer to chapter 6 to learn how to record your voice.

When making a recording, the recording should be performed in an order of 01 - 98 and the process should not be interrupted, that is to say, it is not allowed to record the third section after the first section is recorded. (If the same block is used, the sections can be accumulated automatically as long as the conditions change) e.g. I1 - ON, I2 - OFF and Q=01, the first section is input at the beginning when I1 is ON and I2 is OFF. When I1 is Off and I2 is ON, the first section is turned off.



3.2.14 COMP

Figure in FAB	pin	notes in FAB
	Input 1	comparative input port 1, with 0.0~10.0, I1~IC to be selected.
	Input 2	Function selection <=,>=,>,<=,=
	Input 3	comparative input port 2, with 0.0~10.0, I1~IC to be selected.
	Output Q	with conditions available, output Q is 1 and its selection range is Q1~Q8, M00~M126. Remarks: It may be compared with <=,>=,>,<=,=.

Notes:

Only AF-10MR-D, AF-10MT-D, AF-20MR-D, AF-20MT-D type FABs have this function.

This function is used in the input function block for analog quantity.

Operation of AN function block

The comparison function of AN block is comparison between input 1 and input 3. Such as when you select input 2 as >, it means that when input 1 > input 3, Q will be 1. When input 1 < input 3, Q will be 0.

Example 1 : Input 1 = I1 Input 3 = 050 Input 2 = >, Q = Q1

If $I1 > 5.0V$, then Q1 will be ON

If $I1 < 5.0V$, then Q1 will be OFF

Example 2: Input 1 = I1 Input 3 = I2 Input 2 = <, Output = Q2

If $I1 < I2$, then Q2 will be ON

If $I1 > I2$, then Q2 will be OFF.









FAB Intelligent Control





Chapter IV Programming operation on FAB panel

There are two methods of programming for FAB, one is to complete editing of the function diagram directly on the operation LCD panel using the keys, while the other is to do the same on the computer using the programming software QUICK II . The latter procedure is recommended for more complex control schemes. Programming for FAB can be completed with either of the two methods. This Chapter will describe in detail how to use the operation LCD panel to edit the Function Block Diagram Program and the programming method using QUICK II will be covered in detail in the second part of this manual.

As shown in the following figure, the operation LCD board is a simple man-machine interface and the program editing operation will be completed through the 8 keys on the right:  , , , , , ,  .

The following rules shall be observed for programming operation on this panel:

1. When the cursor appears as an under line, it may be moved:

Move the cursor along the lines with , ,  and  keys;

Press the OK key to confirm selection of the input/output connection or the function block;

Press ESC key to exit the programming input.

2. When the cursor appears as >, the input/output or function block may be selected:

Select the input/output or function block with  and  keys;

Press OK key to confirm the selection;

Press ESC key to return to the previous step.

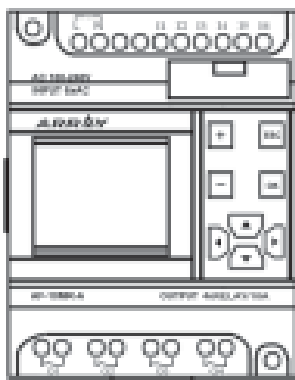

Fig. 4.1

4.1 Display status of FAB

Connect FAB (Fig. 4.1) to the power supply with the method as described in Chapter II. After the power supply is switched on, the LCD panel displays a frame (Fig. 4.2) , which is the Status Display Frame:

the upper line I contains the status values of inputs 1 ~ 6

the lower line Q contains the status values of outputs 1 ~ 4

(in which * indicates ON, i.e. status 1, □ indicates OFF, i.e. status 0.)

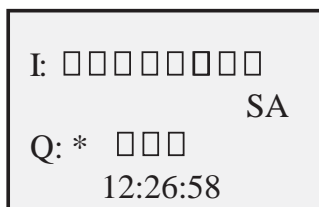



Fig. 4.2 Status Display Frame

4.2 Confirm password

Pressing ESC and OK simultaneously at the Status Display Frame as shown in Fig. 4.2, the user can enter the Confirm Password Frame, as shown in Fig. 4.4. Now it is necessary to input the password value for FAB. The cursor stays at the highest digit of the password, where you can change the digit value (0~9) with the **—** and **+** keys (when you initially press **—** or **+** key, the password value is 0).



Then you can use the  and  keys to change the password input position and input the password values of the remaining digits . If a proper password has been input, you will enter the Editing Frame shown in Fig4.4. If the password is incorrectly input twice consecutively, the Status Display Frame, as shown in Fig. 4.2, will be presented.



Note: The ex-works password is 0001.

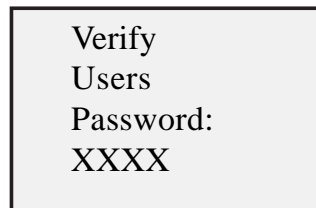



Fig. 4.3 Confirm Password Frame

4.3 Function

Entering the editing frame shown is Fig4.4, the user may use  and  keys to move the arrow > on the left and press the OK key to select the functions, with the following 4 options for selection:

Editor: edit program; Editing Function Selecting Frame shown in Fig. 4.5 will be on when this function is selected;

FAB/Rom: read program, modify the address and reset the modem, etc. the frame shown in Fig 4.19 will be on when this function is selected.

Set: setup RTC real time clock and setup password;

RUN: start running FAB program.

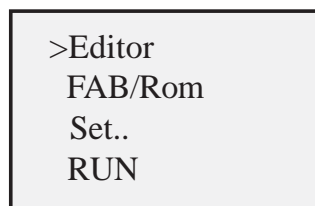



Fig 4.4



4.3.1 Editor

When this function key is selected, FAB will enter the Editing Function Selecting Frame as shown in Fig. 4.5. The user may use  and  keys to move the arrow > on the left and press OK to select the functions.

Edit PRG: Input a function block (consult 4.2.1.1);

Insert FB: Insert a function block into the existing program (consult 4.2.1.2);

Delete FB: Delete a function block from the existing program (consult 4.2.1.3);

Clear PRG: Delete all program block.

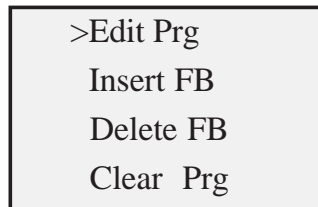



Fig. 4.5 Editing-function Selecting Frame

4.3.1.1 Edit PRG

The Edit PRG Menu Frame is as shown in Fig. 4.6 and the function blocks are to be selected under this menu.

Select Function Blocks:

The user may use the  and  keys to move the arrow > on the left to select the function blocks. Press OK to select a function block, the Function Block Setting Frame shown in Fig. 4.7 will be on (please refer to Chapter III Specification of function Blocks). This menu includes the following function blocks: AND, NAND, OR, NOR, XOR, NOT, RS, UCN, DCN, PLR, MPLR, CPG, RPR, DPR, DDR, CW, TEL, PLAY, MR, ANALOG (D type).

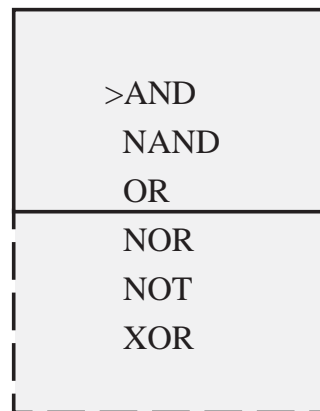

Fig. 4.6 Function-Selecting Frame

Set Function Block:

When the Input Function Block is selected, FAB will automatically help you to define in sequence the numbers of the blocks beginning with B and display the said numbers in the bottom right corner (e.g. B01), as shown in Fig. 4.7.

The user may select the input/output and parameter values to be set up for the function block by moving ▲, ▼, ►, ◄ keys (please refer to Chapter III Specification of Function Block for the input/output/parameter values for different function blocks).

When Selection Output/Input Link is set, press OK to enter the Parameter Setting Status. The user may use ▲, ▼ keys to select the connection point type and for the said output/input, as shown in the top left corner of Fig. 4.7. First move the cursor to I in the top left corner with ◄, ► keys, change the type of the connection point with ▲ and ▼ keys and press OK to confirm it. Then increase or decrease the operand for the connection point with — and + keys (e.g. I0, I1, I2, etc.).

Note: The operands for different types of connection points have different ranges. It is I1 ~ I6 (10 point type) or I1~IC (20 point type) for I (input) and Q1 ~ Q4 (10 point type) or Q1~Q8 (20-point type) for Q (output). Operands are not required for H (high), L (low) and X (empty). M means intermediate relays M00 ~ M99.

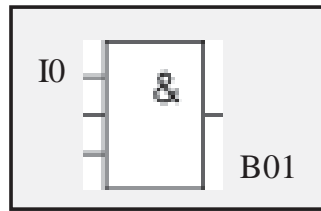

Fig. 4.7 Setting the parameter of function blocks

Described above is the set up of basic function blocks. It is also necessary to explain the setup of the operands for some special function blocks in the following.

1. Function blocks with timing function

Function blocks with timers include:

- DPR: Delay putting Relay
- CPG: Clock Pulse Generator
- DDR: Delay Disconnection Relay
- RPR: Retentive On Relay
- MPLR: Mono-pulse Relay Pulse Relay
- CW: Clock Switch
- PLR: Pulse Relay

When parameter T is set, the following frame will be on the LCD panel

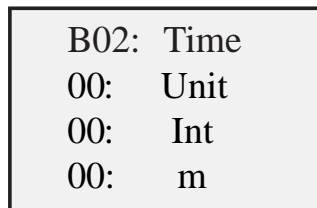

Fig. 4.8

- The line 1: Block number and timing mark
- The line 2: time units— HOU (Hour) , MIN (Minute), SEC (second)
- The line 3: Setting whole number of time (00-99)
- The line 4: Setting decimal of time (00-99)



2. Function blocks with counting function include:

UCN: Up Counter

DCN: Down Counter.

When the PAR is set, the following frame will be on the LCD:

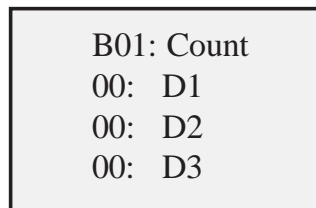





Fig. 4.9

The 1st line represents the block number and counter mark

The 2nd line represents the highest digit of the counting value

The 3rd line represents the second-highest digit

The 4th line represents the lowest digit.

You may set the parameters in turn, as required, by pressing  and  to move the cursor and select the parameters and pressing  and  to change the value.

For example, for setting a number as 967843. D1=96,D2=78,D3=43.

3. Set parameters for the Clock Switch

1) As the date system D is selected, the following will be (displayed) on LCD:

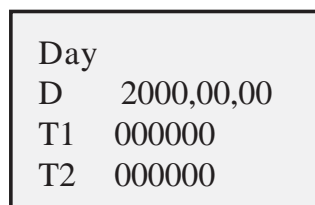

Fig. 4.10



The 1st line represents the date system

The 2nd line represents year, month and day

The 3rd line represents the output ON time (T1).

The 4th line represents the output OFF time (T1).

2) As the week system W is selected, the following will be on the LCD panel:

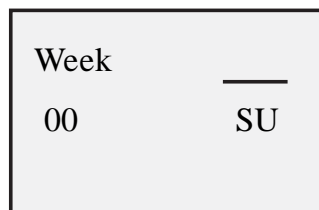

Fig. 4.11

At this time , you can use **+** , **-** keys to select the type of weeks.

MO represents Monday

TU represents Tuesday

WE represents Wednesday

TH represents Thursday

FR represents Friday

SA represents Saturday

SU represents Sunday

MO-TH represents Monday to Thursday

MO-FR represents Monday to Friday

MO-SA represents Monday to Saturday

MO-SU represents Monday to Sunday

FR-SU represents Friday to Sunday

SA-SU represents Saturday to Sunday.



After selecting the week system press the ESC key, you will then be able to select the timing and the following will be displayed on LCD:

Week	
D	2000,00,00
T1	000000
T2	000000

Fig. 4.12

The first line represents the week system

The second line represents year, month and day

The third line represents the output-ON time

The forth line represents the output-OFF time.



Note: You only need set T1, T2, and need not set D when you select the week system the set data will be neglected by the system

4. Set the Telephone Block

When the Telephone Block is selected, the following will be displayed on LCD panel. Set the input on the left of the block first, move the cursor to the output on the right and press OK.

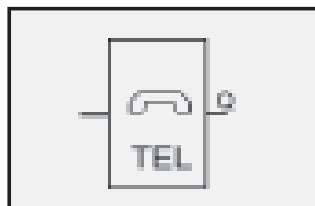

Fig. 4.13



After OK key is pressed, the following will be on the LCD panel:

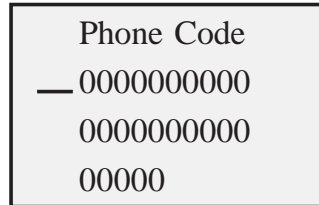









Fig. 4.14

Press , , ,  keys to move the cursor and select the digits of the telephone up to a 25-digit number and press ,  to change the value and set each digit of the telephone number in turn. After the number is set, move the cursor to the last digit of the set number and press  to exit .



*when you complete setting the telephone number, you must add :
marking the end of the number.*

5. Set the AN block

AN block is as follows

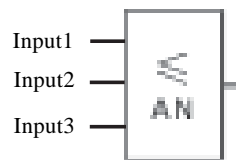

Input 1: I and K are available input.

(1) That the I is selected, it represents this port is connected to FABs -input, whose range is I1~I6 (AF-10 series), and I1~IC (AF-20 series). The operation on the LCD panel is the same as general I. That K is selected represents that digital value, whose range is 000~100 which represents voltage 0~10.0V. The first two digits represent integer , the last digit represent the decimal part.



(2) When input 1 is K or I, press OK to confirm and then to press **+** and **-** to change the digital value. Finally press OK to confirm.

Input 2: It represent s function selection, There are 5 comparison functions which can be selected $>$, $<$, $<=$, $>=$, $=$ Select by using **▲**, **▼** and then press OK to confirm.

Input 3: It is the same as Input 1.

4.3.1.2 Insert FB

This function can be used to insert a function block into a scheduled block position. The operating process is as follows:

1. Press OK at $>$ Insert FB in the Editor Frame, thus the inserting status is entered, as shown in Fig. 4.15.

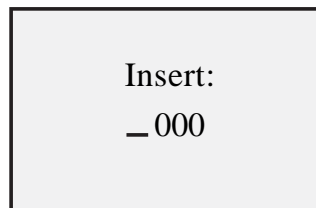

Fig. 4.15 Insert Function Block

2. 000 shown in the above frame is the original value, Press **+** or **-** to select the block number and then press OK to confirm. The range of inserted block numbers is from 001 to the maximum number of the current program If the selected number is not in this range, pressing OK will not be effective and it will return to the original status to let you select a block number in a suitable range. If you want to give up inserting a block, please press **ESC** to exit. If you are not clear about the maximum number in the program ,you can use ROM-FAB in FAB/ROM to read the program and get the number.

3 If you select a right number in the above step and press OK to confirm the number, then machine will affect your operation and function block codes (eg. AND, OR, NOT, RS, TEL,...etc.)will appear for your selection.



Note: If you do not go on selecting but exit, FAB will copy a function block the same block number as the old one. But if you are in the editing step, you can exit only when you finish setting all of the terminals as. You can then delete the block by using Delete FB.

4.3.1.3 Delete FB

This function can be used to delete any function block. The operating process is as follows:

1. Press OK at >Delete FB in the Editor Frame, thus the deleting status is entered, as shown in Fig. 4.16.



Fig. 4.16 Delete Function Block

2. 000 shown in the above frame is the original value. Press **+** and **-** to select the block No. and then press OK. The range of block number for Delete FB is from 001 to the maximum number of the current program. If the selected number is not in this range, pressing OK will not be effective and it will return to the original status to let you select a block number in a suitable range. If you want to discontinue the deleting operation, please press **ESC** to exit. If you are not clear about the maximum number in the program you can use FAB-ROM in FAB/Rom to read the program and get the number.
3. If you have select a correct block number , press OK, FAB will display as follows. It means the selected block has been deleted.



4.3.1.4 Clear Prg

This function can be used to delete all of the existing programs in FAB.

1. In the EDIT frame, Select >clear Prg and press OK, then the following frame will appear .

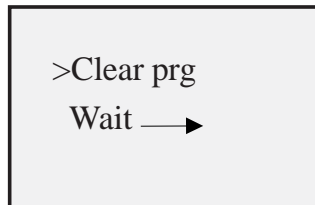

Fig. 4.18 Clear Prg

1. The above frame will last 2~3 seconds, then it will be automatically be on function block selection frame. The old program will have been cleared and you can program again

4.3.2 FAB/Rom

There are three options in Select FAB/Rom Frame, as shown in Fig. 4.17.

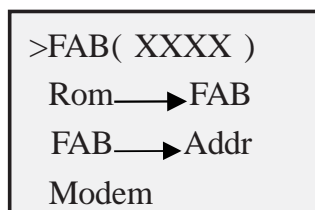

Fig. 4.19



FAB (XXXX): (The series No. of FAB system service)

Rom→ FAB: read the program from FAB

FAB-Addr: view or modify FAB address

MODEM: initialize MODEM.

4.3.2.1 Read program from FAB (Rom>FAB)

1. Select Rom→FAB in FAB/ROM, and press OK, the follow frame will appear.

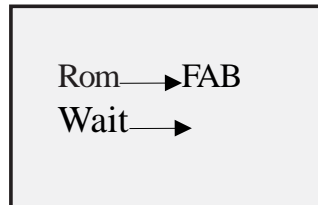

Fig. 4.20

2. Press → in the state shown in Fig 4.20, then the program will be read, block by block (in sequence as B01,B02....)

4.3.3 SET (set password and time)

The SET Frame is shown in Fig. 4.20. A password and real time clock can be set for the edited FAB function program via this SET Frame. When you want to modify the control function, the said password shall be properly input before the editing modification status can be entered (note: the ex-factory password of FAB is 0001). This function is the password lock function of FAB.

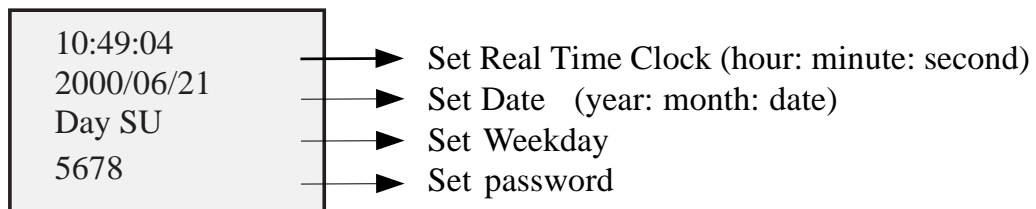

Fig. 4.21 Set Password Frame



Note: If you did not read the FAB's existing program when you edit the program and enter into the editor frame for programming, then it will begin from B01 block. If you want to save the existing program, you should read the program from ROM → FAB and then edit it from editor PRG.

4.4 Edit FAB function program

During editing of FAB function program, special attention need be paid to Some programming rules, the application of the mid-relays (M) marked, or the FAB circuit diagram shall be drawn directly with QUICK II, and then adjust the series No. of the blocks according to Rule 2 and Rule 3.

4.4.1 Programming rules

Rule 1: Before the circuit is input, the complete circuit diagram shall be made on a drawing with the necessary intermediate relays (M) marked, or the FAB circuit diagram shall be drawn directly with QUICK II, and then adjust the series No. of the blocks according to Rule 2 and Rule 3.

Rule 2: The input of circuit is always from input to output, with the cause first and result next. The block sequence number of the cause block must be smaller than that of the result block. The block numbers that have no cause relationship with each other are irrelevant.

Example:

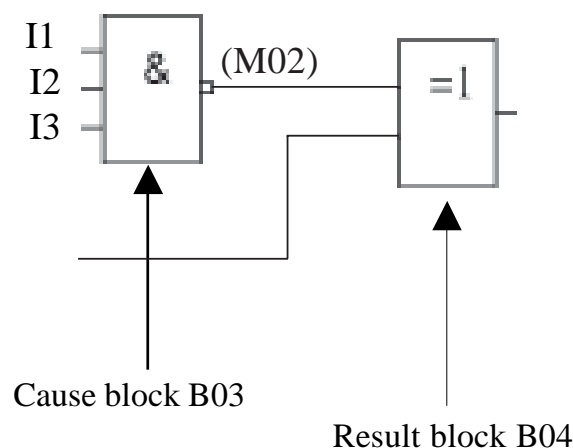

Fig. 4.22



Rule 3: In a program path, an output may be connected to the lead input (for number transfer), but the block with a smaller sequence number shall be used as the lead input (cause block) and the one with a greater sequence number shall be the result block. If the user desires for contrary cause and result blocks it is only necessary to adjust the block sequence numbers.

Rule 4: One output may be connected to multiple inputs, but multiple outputs cannot be connected to one input.

Rule 5: At power-on and initialization of FAB (at the instant of power-on), the intermediate relay (M) and output port (Q) are all in logical 0 status. Their later status will be determined by the program.

Rule 6: It is not allowed to connect two outputs with are end. Such as the following

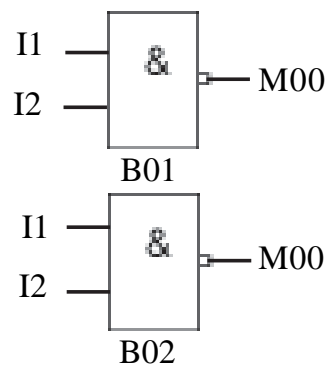

the above is prohibited except for CW block

4.4.2 Middle relay

In FAB programming, the middle is a very important bridge in FAB programming, this is the intermediate relay. The intermediate relay of FAB is similar to that in the relay control system. They can store some intermediate status and then transfer it to a block requiring this status for input. Use of intermediate relays has two advantages:

1. The output terminal of the previous block can be used as the input signal for different blocks;
 2. When a block is inserted or deleted, the original logical relation can be retained.
- The basic functions of the intermediate relay are as shown in the following figure:

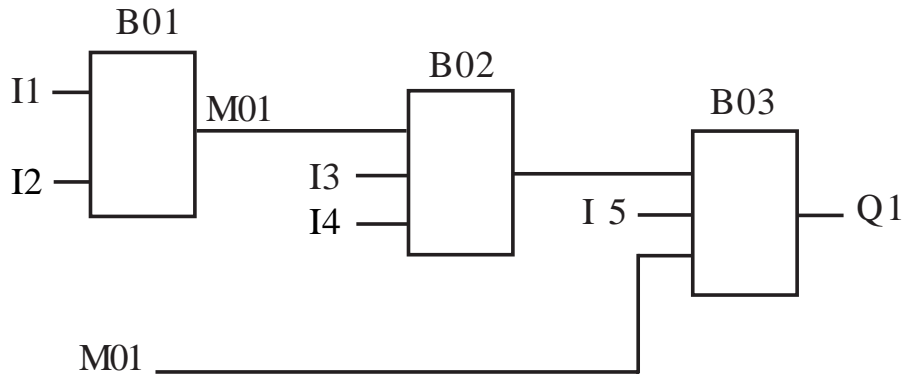

Fig. 4.23

on the above figure, the output status of B01 may not only be used directly as the input of B02 block, but also be stored by M01 and then used as the input of B03.

4.4.3 Edit program

Take the stair lighting system for an example, with the following control requirements: 1. When the switch button is pressed, the light will be turned on and kept normally on; 2. When the sound sensing switch is on, the light will be turned on and kept on for 2 minutes.

The Function Block Diagram for the said control function is as follows:

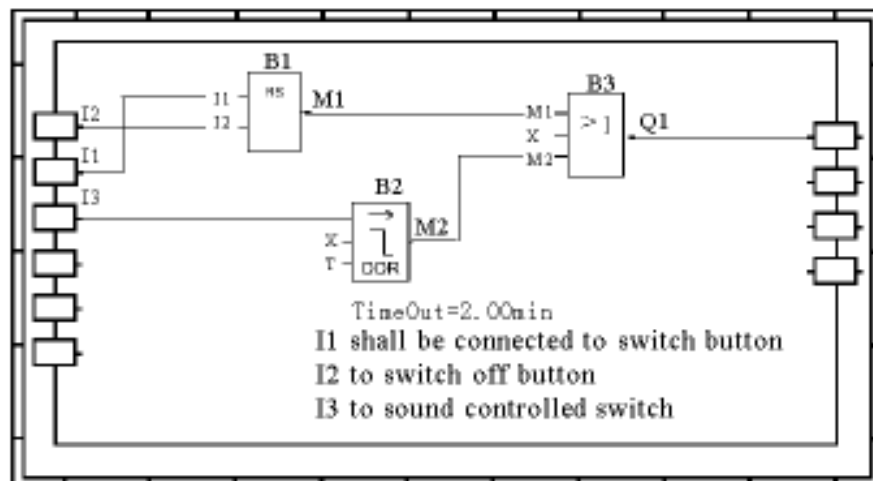

Fig. 4.24



The following procedure shall be followed for editing of the said control function with FAB operation panel:

In case a user program already exists in FAB:

Step I: Enter FAB Editor Frame

1. In 2 ~ 3 seconds after switch-on, the following will be on the LCD panel:

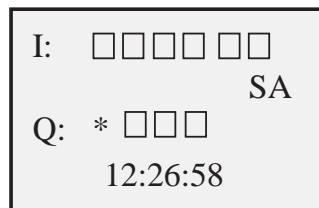

Fig. 4.25

2. After **ESC** and **OK** are pressed simultaneously, the Confirm Password Frame is entered, At this time the cursor will stay at the highest digit of the password and the following will be displayed on the LCD panel:

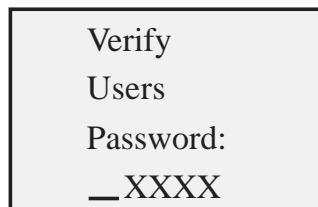

Fig. 4.26

3. Input the password, with the password assumed as 2165;

Press **+** twice and the first digit value of the password will change to 2;

press right moving key **▶** and the cursor will move one digit to the right for the second digit of the password value to be input;

press **+** once and the second digit of the password value will become 1;

press **▶** and the cursor will move one digit to the right for the third digit of the password value to be input;



press **+** 6 times and the third digit of the password value will become 6;

press **▶** and the cursor will move one digit to the right for the last digit of the password value to be inputted;

press **+** 5 times and the last digit of the password value will become 5.

After the password is completely input, the following will be displayed on the LCD panel:

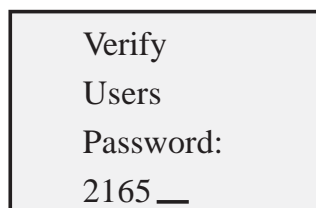

Fig. 4.27

4. Press **OK** to enter the Select Editing Function Selection Frame, with the selection mark > staying at Editor function. The following is displayed on the LCD panel:



Fig. 4.28

Step 2: Edit Function Diagram

1. Press **OK** to select Editor and the Function Block Selection List is entered. The following is displayed on the LCD panel:

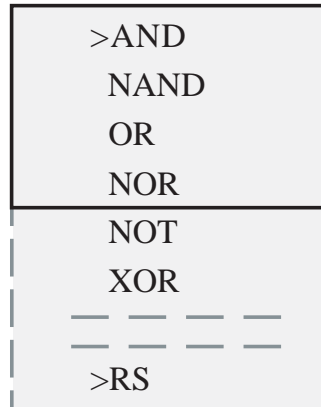

Fig.4.29

2. Select and set the first function block:

Move > to the position of RS relay with and press OK to enter the Function Block Set Status, when the cursor is at the highest input Link. The following will be on LCD panel:

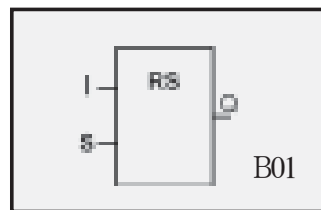

Fig. 4.30

Press and the Set Parameter R link input status will be entered. Now I will appear at R link. If you do not want to select I, you may press to select Q and press it again to select H and may continue with the same until M. It means that the user may select any parameter among I, Q, H, L, C, P and M by pressing . After I is selected, the following will be on the LCD panel:

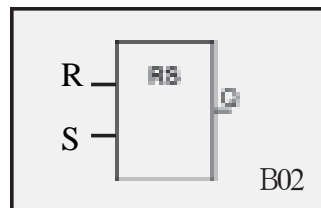

Fig. 4.31



Then it is necessary to set the parameters, namely to set the values with **+** , **-** . For example, if I1 is to be set up, just press **OK** key when I1 is displayed, as shown in Fig. 4.31 (the variation range of I is I1-I6 or I1-IC).

Press **▶** to move the cursor to position S and press **OK** to set the S link input. Selecting I in the parameter list and set it to I2 by the same method as setting I1 and pressing **OK** once. The LCD panel will be as Fig. 4.32.

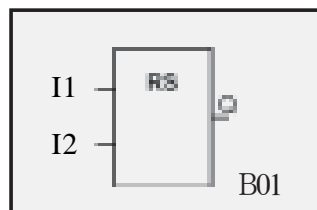

Fig. 4.32

Press **▶** to move the cursor to position Q and press **OK** to set the Q link output. After selecting M in the parameter list and set it to M01 with **+** , **-** , press **OK** again. The following will be displayed on the LCD panel:

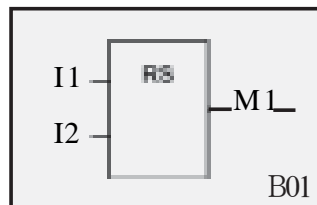

Fig. 4.33

Now, all the three links and edit the following blocks of the RS relay function block are set Then press ESC to exit this block.



Note:

When you enter the edit function block, you cannot exit to the 1-level higher programming interface by pressing ESC or the OK unless you have set all the links of this block (including all the I/O links)



3. Select and set the second function block

Press **ESC** to return to the Function Block Selection List Frame and select the second function block.

Move > to the position of DDR function block and press **OK**. Now you can set the parameters for the function block. The following will be on the LCD panel:

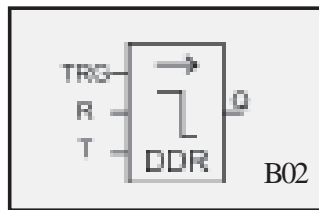

Fig. 4.34

Press **OK** to enter Set Trg Pin Parameter Status. Select I in the parameter list with **▲**, **▼** and press **OK**. Then set Trg to I3 with **+**, **-**. The following will be displayed on the LCD panel:

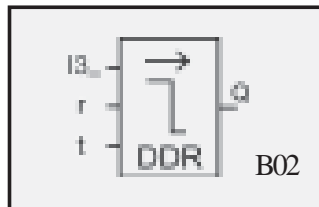

Fig. 4.35

Press **▼** to move the cursor to position R and press **OK** to set the r input parameter. After selecting **°OK±** in the parameter list, press **OK** to set the parameter X. The following will be displayed on the LCD panel:

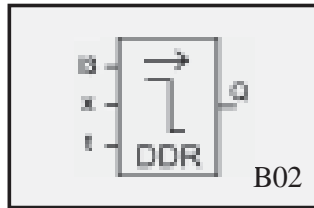

Fig. 4.36

Press to move the cursor to position T and press to enter the Set Timer Frame. The following will be displayed on the LCD panel:

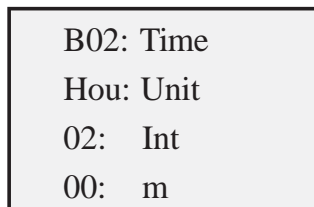

Fig. 4.37

Press to enter the Time Unit Selection Status. Now the options can be changed with , . When "min in" appears, press to set the time unit as minute. The following will be displayed on the LCD panel:

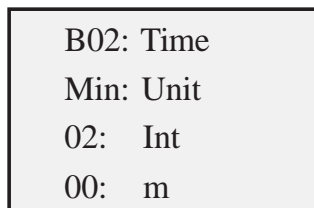

Fig. 4.38

Press to set the time integer digit and use , to change the value. Set it as 02.

Press to set the time decimal digit and use , to change the value. Set it as 00. Now the time is set to 2 minutes. Press and then press ESC to exit.



Press **▶** to move the cursor to position Q, press **OK**. Set Q as M02 and then press **OK** again. The following will be on the LCD panel:

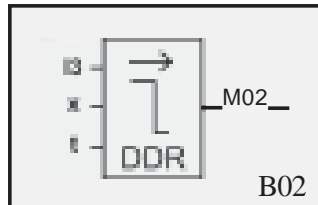

Fig. 4.39

Select and setup the third function block

Press **ESC** to return to the Function Block Selection List Frame and select the third function block.

Move **>** to the position of OR function block and press **OK**. Now you can set the parameters for the third function block. The following will be displayed on the LCD panel:

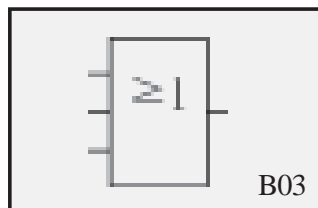

Fig. 4.40

Press **OK** to enter the first input parameter set status. Select parameter M with **+**, **-** and set the parameter value with **▲**, **▼**. When M01 appears, press **OK** and the first parameter will be set to M1. The following will be on the LCD panel:

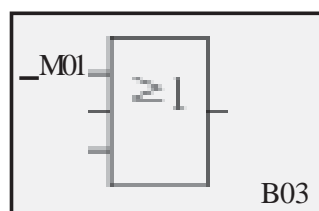

Fig. 4.41



Press to move the cursor to the second input parameter and press . Now the second input parameter can be set. After selecting X with , and pressing , the said input is set to X. The following will be displayed on the LCD panel:

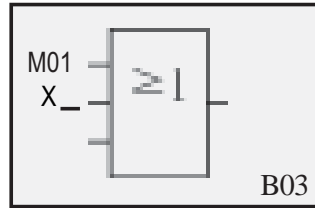

Fig. 4.42

Move the cursor to the third input link and press . After selecting M in the parameter list, press and set the said input to M2 with , . The following will be on the LCD panel:

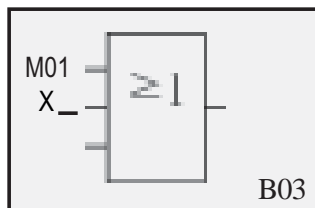

Fig. 4.43

Move the cursor to the output link with and press . After selecting Q in the parameter list, press and set the said output link as Q1 with , . The following will be displayed on the LCD panel:

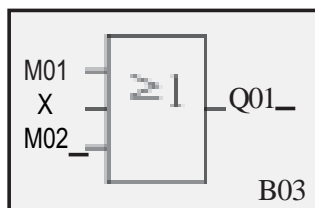

Fig. 4.44



Now all the three function blocks required for editing of this function diagram are selected and set, which means that the Function Diagram is completely edited.

Step III: Run

1. After Set up II is finished, press **ESC** twice consecutively to return to the Select Function Selection. The following will be displayed on the LCD panel:



Fig. 4.45

2. Move> to RUN and press **OK** The following will be on the LCD panel:



Fig. 4.46

3. It means that the program is now written into FAB and can be run according to the new program.



Notes:

How to read and modify the current program.

Press ESC and OK simultaneously to enter the password frame, and then enter the correct password, and then press OK.

Select FAB/ROM and press OK

Select ROM -FAB, and then press OK

Press  and  to select and read the function block, and press OK to confirm and to make the modification.

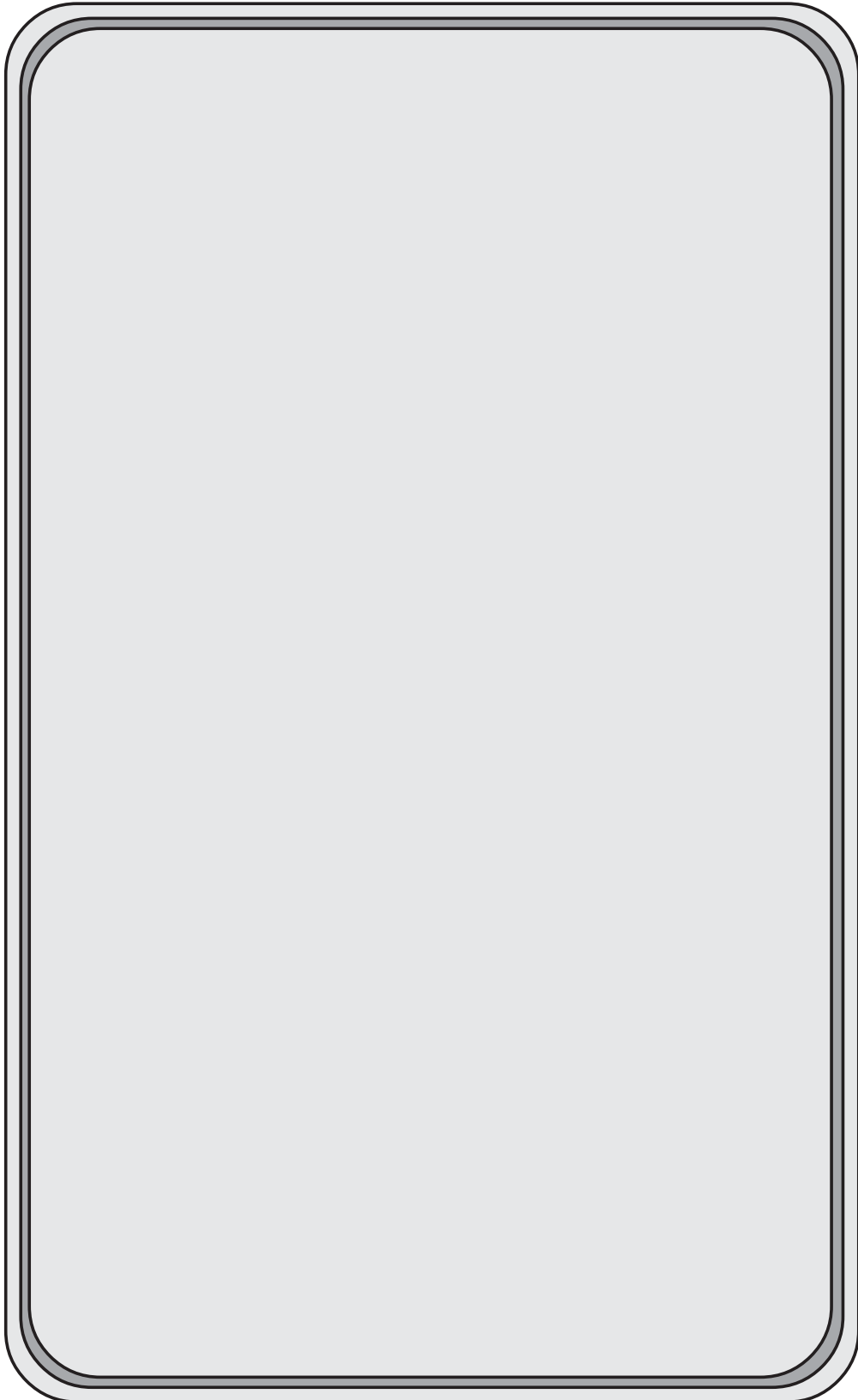



Chapter V Remote programming and monitoring

5.1 Remote programming and monitoring via a MODEM

FAB can realise ultra-remote programming and monitoring function through a MODEM. If you need to program or monitor a FAB on a work site kilometers away or even between two cities, this function of FAB will satisfy your requirement.

After the connection of FAB, AF-C232 (or AF-MUL), AF-M232 and MODEM (refer to 5.2 for details of the connection diagram), switch on the power and the MODEM will automatically complete the initialization. If the MODEM is not initialized, you may press **OK** on the MODEM menu under FAB/ROM of the LCD programming interface to initialise it.

Connect the MODEM to a computer provided with QUICK II or FAB-SCADA software and make a connection with FAB by dialing the telephone connected to FAB through the computer. Remote programming and monitoring can now be carried out.

Note: AF-M232 is a standard Array product.

AF-M232 is a standard DB9 \longleftrightarrow DB9 connection.

The Cable Connection Diagram for AF-M232 is as follows:

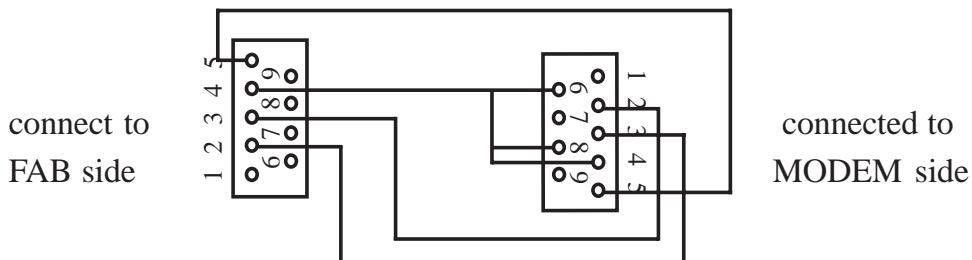



5.2 Two connection methods for FAB remote programming and monitoring

5.2.1 Connect MODEM by means of AF-C232 and AF-M232

For connecting with this method, you will need the following parts: AF-C232 and AF-M232. The connection diagram is as follows:

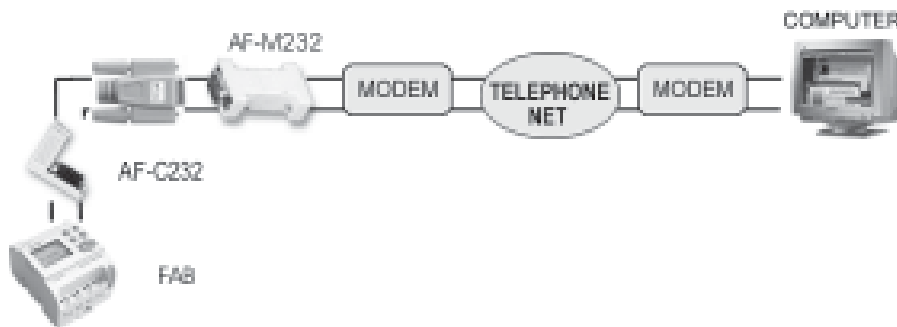

5.2.2 Connect MODEM by means of AF-MUL

If you have the AF-MUL telephone and voice multifunction block, it is not necessary to have the AF-C232 part. The connection diagram is as follows:

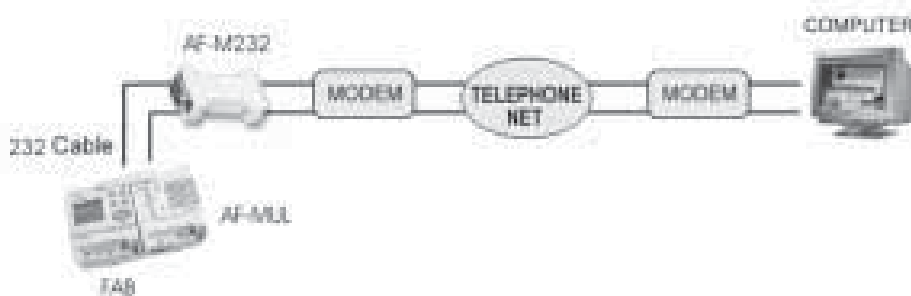

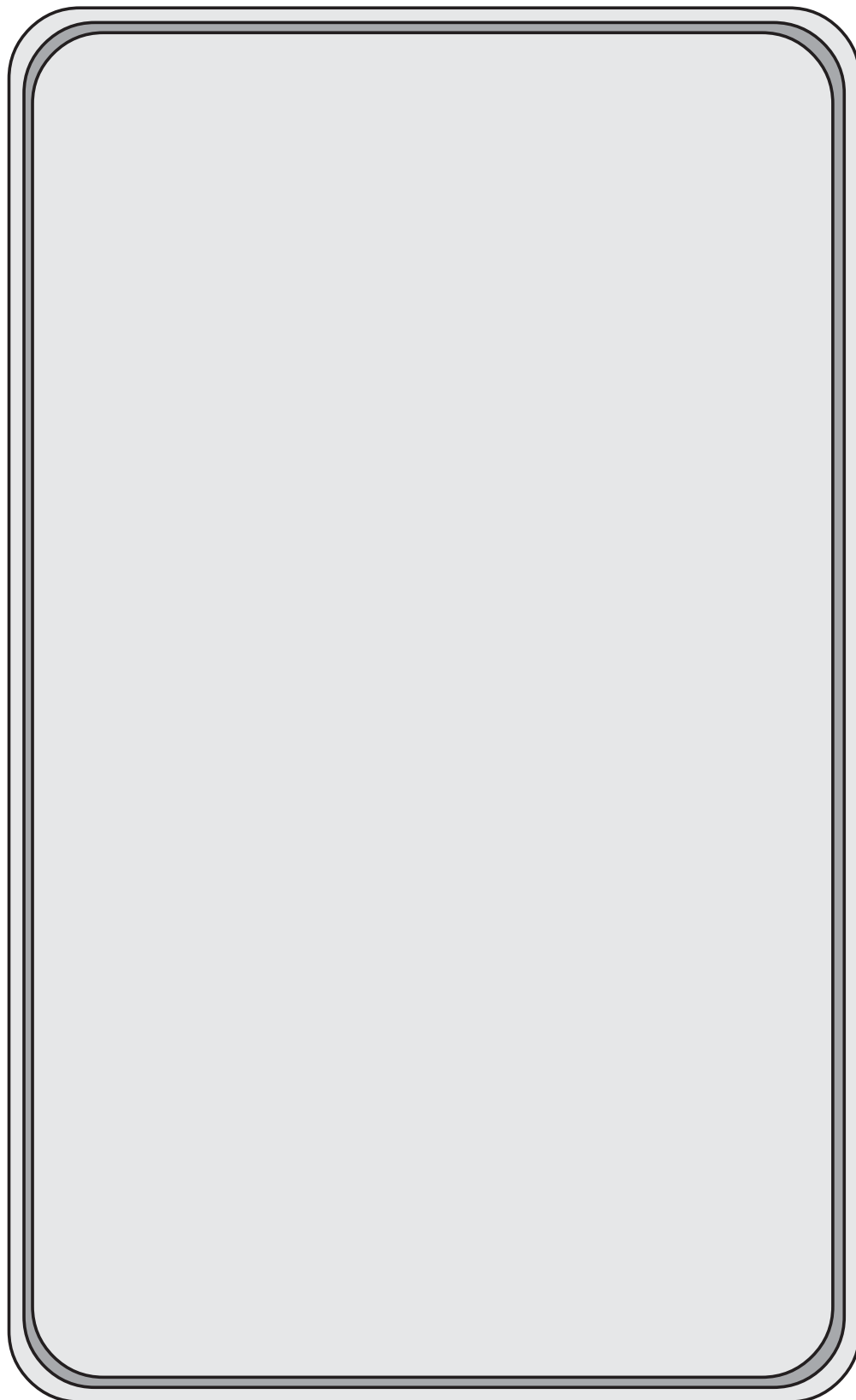



Chapter VI Voice Module

Voice alarm function, telephone control function and dialing automatically function are very important functions of FAB. To realize these functions, we should match FAB with the AF-MUL telephone and voice multifunction block.

6.1 The structure of the voice module:

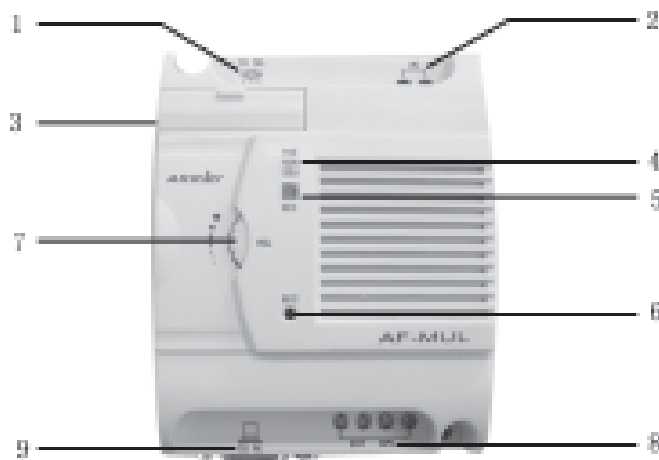

Fig 6.1 Structure of AF-MUL

1. Socket of telephone crystal plug
2. Power terminals (AC100-240V) or (DC12-24V)
3. Connecting Port with FAB
4. Power indicator
5. Recording indicator
6. Recording Microphone
7. Volume control 1 (controls the volume of AF-MUL Speaker)
8. Terminal port for external speaker (it can be connected to an externally powered-speaker to amplify the voice, the volume is not controlled by 7 (Volume control))
9. Communication Port: Connected with the computer to monitor or program the FAB or Connected with a MODEM via M232 part to remote monitor FAB (the same function with AF-C232 part).



6.2 Connection between AF-MUL and FAB.

Connect the power to the AF-MUL and FAB and then plug the telephone connector into the TEL socket . Connect the AF-MUL and FAB by using the special connection. (Please use the link connection provided forming part of the AF-MUL supply). As figure 6.2 shows.

For convenient installation there is a DIN rail clamp on the bottom of the AF-MUL. Both AF-MUL and DAB can be readily installed on a common DIN rail.

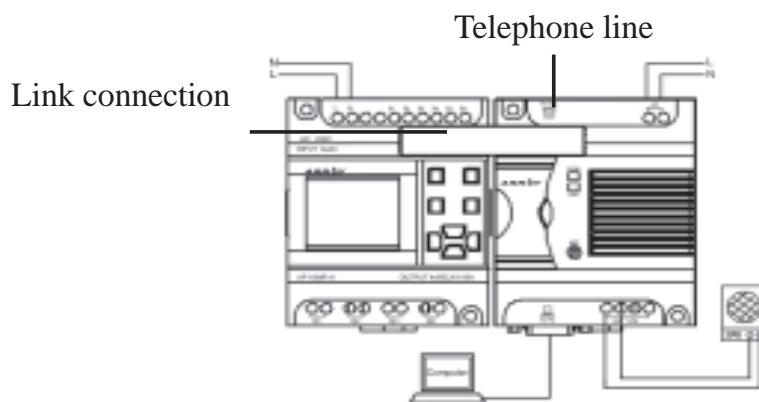

Fig 6.2 Connection Between FAB and AF-MUL

Note: (Before recording or amending the voice messages, you should use a 232 cable for the communication between computer and AF-MUL telephone and voice multifunction block (FAB and AF-MUL) as shown in above diagram.

6.3 Guide for using the voice multifunction block

1. The first four sections (section 0, section 1, section 2, section 3, are for the voice system, users can not record the four sections randomly.

Section 0, is the prompt voice for confirming the user status , It will be broadcast only when the AF-MUL system number has been dialed.

Section 1, is the prompt voice for confirming the input of this section and it can not be broadcast without using the correct password .It will be broadcast when the correct password is input. Normal broadcasting can be carried out with this section.

Section 2, is the prompt voice for the wrong password .It will be broadcast when the wrong password is used. Normal broadcasting can be carried out with this section.



Section 3: is the prompt voice for dialing to a connected telephone. It will be broadcast when the FAB dials a connected telephone. Normal broadcasting can be carried out with this section.

2. The usage of the four special sections.

For example: users can use four message sections as follows.

(1) Record section O as **Please enter the password for confirmation**

Record the 1st section as **correct password**. You can then carry out the next step.

Record the 2nd section as **wrong password**. You can then re enter the password.

Record the 3rd section as **Alarm** You can then enter the password and carry out the real time control.”

(2) When a user dials the FAB system number, AF-MUL will answer the telephone automatically and broadcast -please enter the password for confirmation, then the user enters the password.

A. If the entered password is correct, FAB system will then broadcast-correct password-please do the next step to control. Then the user can control the equipment by use of the telephone.

B. If the entered password is not correct the FAB system will broadcast-wrong password , please re-enter. The FAB system will then broadcast the section 0 message repeatedly.

(3) When the FAB voice system dials a preset telephone number, it will broadcast the preset message such as the 4th section Gas leakage alarm together with the 3rd section Alarm, please enter the password to control.

A. When user enters the correct password, the voice system will broadcasts the 1st message and then will broadcast the 4th message repeatedly. At this time the user can real-time control the equipment by use of the telephone.

B. When the user enters a wrong password, the voice system will broadcast the 2nd message-wrong password, please re-enter, The voice system will then broadcast the 3rd message and 4th message repeatedly.



Notes:

- A.** *When a connected telephone is dialed by the FAB voice system, if there is no answer or a password is not input within 40 seconds of the connection the FAB voice system will stop dialing and cease to broadcast the voice message. The FAB voice system will then redial automatically every 20 seconds.*
- B.** *User must enter a * before entering the password. The broadcasting will then stop and the user should enter a four-digit password within nine seconds. If the user fails to enter the password, the FAB voice system will rebroadcast the prompt voice. The user must then enter * first and then enter the password, if the user needs to enter the password again the procedure needs to be repeated..*
- C.** *When the user has entered the correct password, the voice system will broadcast the 1st section-correct password-please do the next operation. The user can then carry out the following operation. If the password is wrong, the voice system will broadcast the 2nd message-wrong password -please re-enter. The user can only enter the wrong password twice. If the user enters the wrong password for the third time, FAB will hang up the telephone and stop broadcasting. The FAB will then return to the main system. If the alarm status still exists, the voice system will dial automatically, for alarm purposes, every 20 seconds.*
- D.** *When the alarm status exists, FAB will broadcast the alarm voice repeatedly every 20 seconds, it can be stopped by the use of the control function within the program.*
- E.** *When the broadcast has stopped the user should enter the four-digit password within nine seconds. If the user fails to enter the correct password, the FAB voice system will rebroadcasting the prompt voice. The user must then enter * first and then the four digit password within nine seconds after the broadcast has ceased.*
- F.** *After FAB has dialled out if the user does not switch-off the alarm ON/OFF switch via the anti-control function i.e, the cause for alarm is not corrected the FAB will dial, for alarm purposes, automatically every 20 seconds.*



6.4 Recording

The recording function of AF-MUL is similar to a voice message telephone or recording machine. Then, how to record? The FAB provides a record function MR block. The method for using the MR block is as follows

When ON is 1 and OFF is 0, begin the voice recording.

When ON is 0 and OFF is 1, stop the voice recording.

The recording range of output Q is from 0 to 98 messages and the inputting of voice messages must be sequential.

Notes:

The user shall record messages in a progressive sequence from 0 to 99. The sequence cannot be changed. For example, it is not possible to record the third message after the first message. The user should record the third message after the second message and so on.

Message 0 (base section) is for prompt words. When the user dials the voice module, the user will hear the base section prompt voice message. This voice message through the telephone is not controlled by the play function.

When output Q is 99, it does not mean that the user can record the 99th message. Q 99 is used to wipe away all of the recorded messages. Output Q 99 is similar to the delete button of recording machine. The user must delete all originally recorded messages within the AF-MUL before commencing a new set of voice recordings.

Example: The user wants to record voice messages as follows:

The 0 base section message-Please enter the password.

The First section message-correct password, please enter the message code.

The Second section message-wrong password, please re-enter again.

The third section message-emergency, please enter password to control

The Fourth section message- Whatever message four is.

And so on to the system needs.

The voice message recording operation of is as follows:

1. As shown in Fig 6.4, connect the AF-MUL and FAB, connect switch k1 between L and I1, connect k2 between L and I2, connect k3 between L and I3 and connect k4 between L and I4.

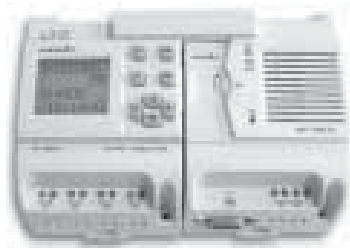

Fig 6.3

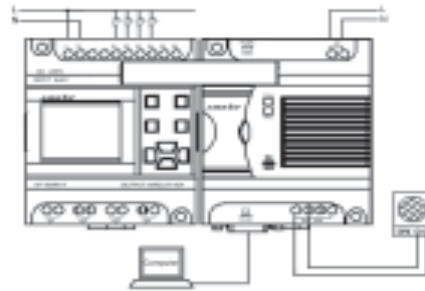

Fig 6.4

2. Switch on the power of FAB and AF-MUL, Write the two function blocks program in FAB when they run.



3. Run the FAB and close the switch k1 one second and open it, then close switch k2, one second and open it, then the original recording of FAB is deleted.
4. Close k3 for one second and open it, the user will see that the red recording indicator light of the AF-MUL is on, user to say-Please enter the password into MIC of the AF-MUL, then close k4 for a second and then open it. Now the user will hear the recorded voice-Please enter the password. The voice message is broadcast by the AF-MUL and proves that 0, the base section voice message has been recorded in the AF-MUL.
5. Close k3 for one second and then reopen it, the user should then close k3 again for one second again. When the red recording indicator light is on, user to say the second section voice message into MIC of the AF-MUL. This will complete the second section voice recording.
6. Repeat 5 above for additional voice messages until all sequential voice recordings have been completed.



6.5 Sound broadcasting

Write the sound playing FB into the FAB and set up the property. Set up the relevant broadcasting voice section, section 04 and section 08, as follows:



When the program has been written into FAB, and the FAB run, turn on the switch K1 for one second then turn it off. At this time you will hear-the fourth section voice, then turn on the switch K2 for one second then turn it off and the broadcast will be closed.

Turn on the switch K3 for one second and turn it off, you will hear -the eighth section-you recorded voice. Turn on the switch K4 and then turn off, the sound will be closed.

Notes: If the two broadcasting function blocks are both actioned, the function block with bigger number will be broadcast, which follows the principle - the later-command takes precedence over the earlier command.

6.6 Telephone remote control function

If the user wants to control distant equipment by mobile telephone or touch dial telephone, the user should connect FAB to AF-MUL, as shown in figure 6.2. Because FAB has an RS block which can be driven by the double-tone information. Signal (P0-P9), the user only needs to write the program with an RS block in FAB and it will work.

For example, if you want to let the P3 button control the Q2 of FAB, the user should write the following program into FAB beforehand. The AF-MUL broadcasts firstly a prompt voice (that is the recorded ground message) when the user dials the telephone number connected to an AF-MUL

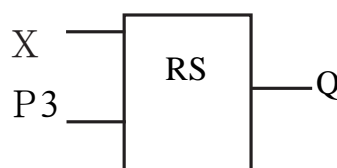



Notes:

1. When the user enters the password, the system will prompt-Please enter information code. Press 3 on the telephone, then the output Q2 is connected
2. When you enter your password or other control signal code, you should enter * before the number code.
3. If you want to disconnect the telephone, press # twice.
4. The system will shut down if there is action for 30 seconds or if a wrong password is entered.

6.7 Automatic dialing function

If you want to use the FAB to automatically dial alarm number, 112 or some telephone number, in emergency, use the procedure as follows.

First, connect FAB with AF-MUL. As figure 6.2.

Second, use the TEL block when you are programming. Write the number that you want to dial in advanced, for example 34568. The system will dial the number automatically when I1 receives the signal:

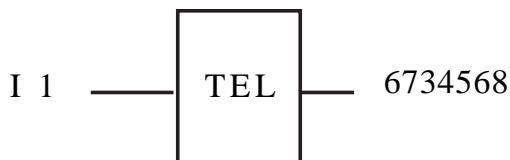

6.8 Example for using the voice module for control and security

Control requirement:

First, control the home electrical equipments by the telephone's buttons.

P0: The air-conditioner is turning on

P1: The air-conditioner is turning off

Second, a sensor is fitted to doors and windows. If there is an illegal entry the voice module will be activated with the prerecorded message- Seize the thief. It will also automatically dial your designated telephone for alarm purposes.

In order to establish the control in the above examples the user should set the voice module as follows:

0: Please enter a password.



- 1: Correct password, please enter control information code.
- 2: Wrong password. Please enter again.
- 3: Emergency, please enter the password and control message.
- 4: Turn on the air-conditioning.
- 5: Turn off the air-conditioning.

The first step: refer to section 6.3, record the above six voice messages.

The second step: connect IO with the doors and windows sensors.

The third step: edit program as follow.

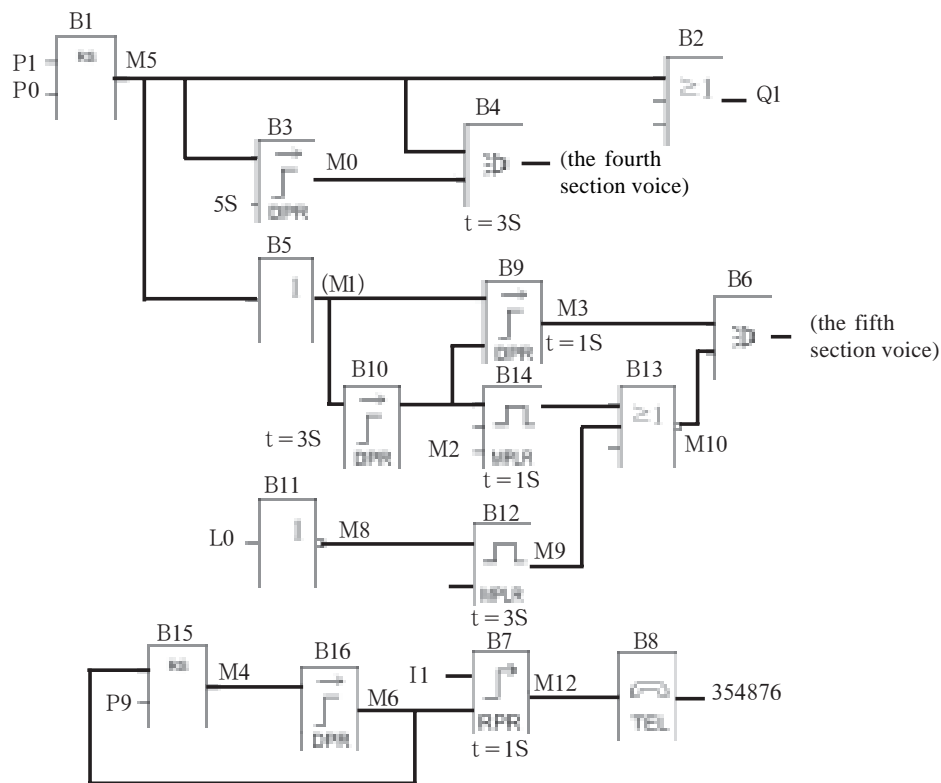

The user will now have completed the connection and installation of FAB, AF-MUL and ancillary parts. The voice recording and programming will also have been completed.

When the user dials the number which the AF-MUL is programmed to connect to the user will hear-Please enter password. The user should enter * and then the correct password.



Then the user will hear the prerecorded message-Please enter the control information password, and should then enter * 0. The user will then hear- Turn on the air conditioner. The air-conditioning will be simultaneously turned on. Similarly the user could enter * 1. The user will then hear-Turn off the air conditioner. The air conditioning will then be simultaneously turned off. Subject to the extent of the programming if the user enters * 3 the user will hear-Turn on the hot water heater. The hot water heater is simultaneously turned on. When the user enters * 4 the user will hear-Turn off the hot water heater. The hot water heater is simultaneously turned off. If switch I1 is activated, the prerecorded voice message-Seize the thief-will be broadcast and the preset telephone number dialed for remote alarm.

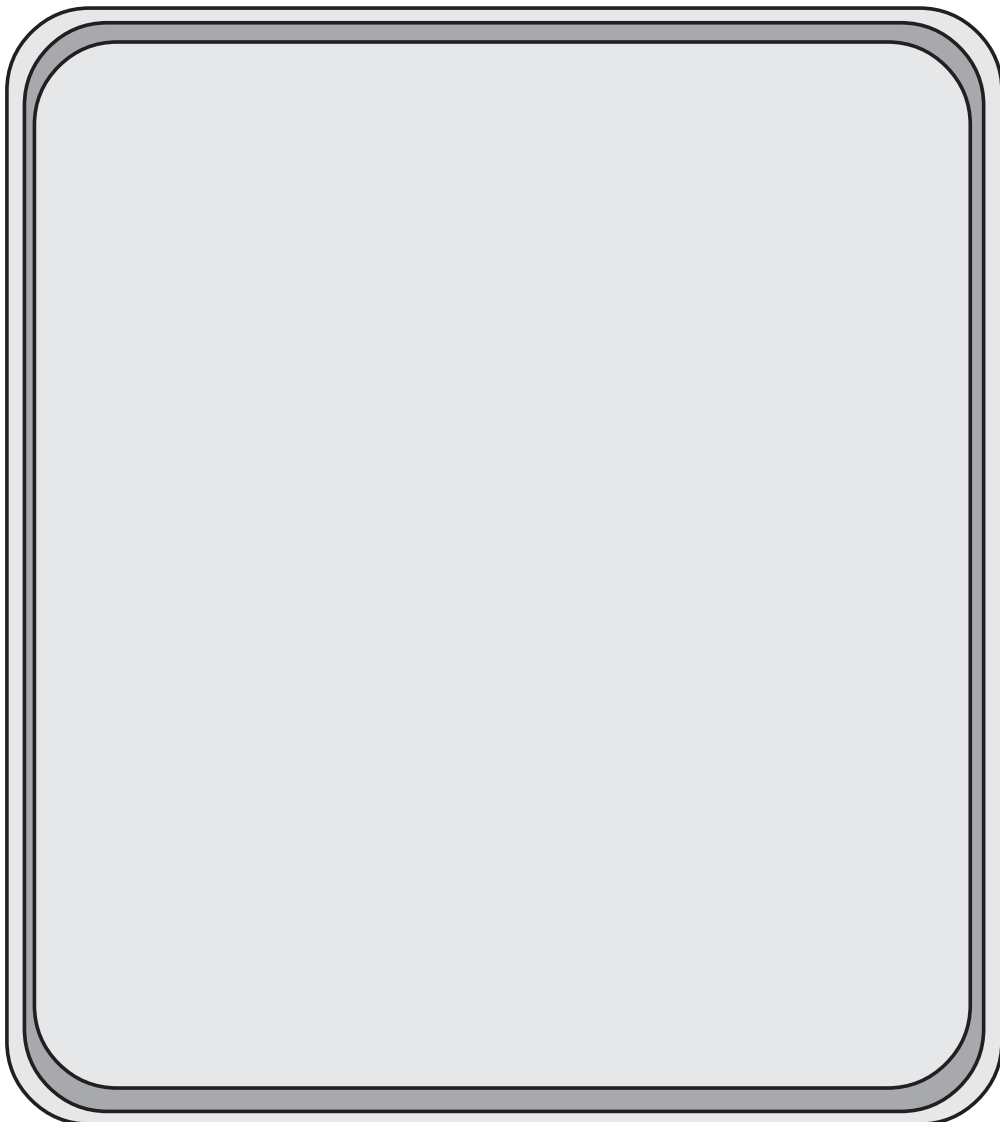



Chapter VII Technical specifications

7.1 General technical specifications

Item	basis	condition
Climate environment		
ambient temperature	cold: IEC68-2-1, hot: IEC68-2-2	
Horizontal installation		0 ~ 55;æ
vertical installation		0 ~ 55;æ
Storage/transportation		-40;æ ~ +70;æ
Relative humidity	IEC68-2-30	5% ~ 95%, without condensation
Atmospheric pressure		795 ~ 1080kpa
Pollutants	IEC68-2-42 IEC68-2-43	H2S1cm3/m3, 4days SO210cm3/m3, 4days
Mechanical environment		
protection type		IP20
Vibration 2	IEC68-2	10 ~ 57Hz (constant amplitude 0.15mm) 57 ~ 150Hz (constant acceleration 2g)
Impact	IEC68-2-27	18 impacts (semi sine 15g/11ms)
Fall	IEC68-2-31	falling height 50mm
Freely falling body (with package)	IEC68-2-32	1m
Electromagnetic compatibility (EMC)		
Static discharge	severe grade 3	8kv air discharge, 6kv contact discharge
Electromagnetic field	IEC801-3	field strength 10V/m
Interference suppression	EN55011	limitation grade B group 1
Shock pulse	IEC801-4 severe grade 3	2.2kV for power line 2.2kV for signal line
IEC/VDE safety information		
Insulation Intensity	IEC1131	meeting the requirement



7.2 AF-10MR-A / AF-20MR-A

Power Supply	AF-10MR-A	AF-20MR-A
Allowable range of 8 input voltage rating VDE0631: EC1131: Allowable main frequency	110/240VAC 85V ~ 250V AC 85V ~ 256V AC 47 ~ 63Hz	
250° Clock buffer memory	100 hours	
Real time clock accuracy	Typical ±1s /day	
Power consumption	AF-10MR-A (3W) AF-20MR-A (5W)	
Data Capacity Input		
Input Voltage L1 Signal 0 Signal 1	0V ~ 40VAC 80V ~ 250VAC	
Input Current Signal 1	Typical 0.24mA at 230VAC	
Delay Time Changed From 1 to 0 Changed From 0 to 1	Typical 50ms Typical 50ms	
Length of Power Line (without shield)	100m	
Data Capacity Output	Yes	
Output Type	Relay Output	
Electrical Isolation	Yes	
Group	1	
Continuous Current Ith	Max. 10A	
Incandescent Lamp Load (25,000 switch cycles)	1000W (230/240VAC) 500W (115/120VAC)	



Fluorescent Light Tube With Electrical Controller (25,000 Switch Cycles)	10 x 58W (230/240VAC)
Fluorescent Light Tube With Regular Compensation (25,000 Switch Cycles)	1 x 58W (230/240VAC)
Fluorescent Light Tube Without Compensation (25,000 Switch Cycles)	10 x 58W (230/240 VAC)
Short Circuit Protection cos 1	Power Supply Protection B16 600A
Short Circuit Protection cos 0.5 ~ 0.7	Power Supply Protection B16 900A
Output Relay Protection	Max. 20A Feature B16
Switch Frequency	
Machine	10Hz
Resistor Load / Lamp Load	2Hz
Induced Load	0.5Hz

7.3 AF-10MT-D / AF-20MT-D

Power supply	
Input Voltage	24VDC
Rating	20.4V ~ 28.8VDC
Allowable Range	
24VDC Power Consumption (Output Full Load)	Typical 1.23A
Digital value input	Typical 0.6W
Data Capacity Input	
Input Voltage (24VDC)	24VDC
Rating	24VDC
Signal 0	<5.0V DC
Signal 1	>15.0VDC



Input Current for Signal 1	Typical 3mA
Delay Time Changed from 1 to 0 Changed from 0 to 1	Typical 50ms Typical 50ms
Length of Power Line (Without Shield)	100m
Data Capacity Output	
Output Type	Crystal Tube Current Source
Output Voltage	$\leq 80\text{VDC}$
Output Current	Max. 0.3A
Short Circuit Protection and Overload Protection	Yes
Short Circuit Current Limit	Approximately 1A
Rating Reduction	Rating is Not Reduced in the Whole Temperature Range

7.4 AF-10MR-D AF-20MR-D

Power Supply	
Input Voltage Rating Allowable Range	24V DC 20.4 ~ 28.8VDC
Power Consumption of AF-10MR-D / AF-20MR-D at 24VDC	Typical 1.5W
Data Capacity Input	
Input Voltage Rating Signal 0 Signal 1	24VDC 24VDC <5.0V DC >15.0V DC
Input Current for Signal 1	Typical 3mA
Delay Time Changing from 1 to 0 Changing from 0 to 1	Typical 50ms Typical 50ms



Length of power line (Without Shield)	100m
Data Capacity Output	Digital Value Output
Output Type	Relay Output
Electrical Isolation	Yes
Group	1
Continuous Current Ith	Max. 10A
Incandescent Lamp Load (25,000 switch cycles)	1000W
Fluorescent Light Tube with Electrical Controller (25,000 switch cycles)	10 x 58W
Fluorescent Light Tube with Regular Compensation(25,000 switch cycles)	1 x 58W
Fluorescent Light Tube without Compensation(25,000 switch cycles)	10 x 58W
Short Circuit Protection cos 1	Power Supply Protection B16, 600A
Short Circuit Protection cos 0.5 ~ 0.7	Power Supply Protection B16, 900A
Parallel connected Output for increased Power	Not Allowed
Output Relay Protection	Max. 20A Feature B16
Switch Frequency	
Mechanical	10Hz
Resistor Load/Lamp Load	2Hz
Induced Load	0.5Hz

7 . 5 Telephone number receiving, transmitting and voice blocks

Index	Conformity
Automatic Receive	CCITT-DTMF
Automatic transmit	CCITT-DTMF
Voice Record and Play	Max. 98 segments, Each with Arbitrary Time (16min)





Chapter VIII Application

FAB has a very wide application range. In order to let the user consider the wide application potential for FAB and the convenience brought about by its use, we will show some common and representative control schemes herein. After the user has read these application examples it will be clear how simple it is to use FAB to establish automatic control requirements, especially in a system requiring time control and in the automatic control of intelligent living quarters etc.

8 . 1 Bell control for schools, factories and the like

Control requirements:

Monday to Friday: 6:00:00 to 12:00:00 AM, the bell shall ring once every hour for 10 seconds; 14:00:00 to 17:00:00 PM, the bell shall ring once every hour for 10 seconds.

Saturday and Sunday: 8:00:00 to 12:00:00 AM, the bell shall ring once every 2 hours for 10 seconds; 13:00:00 to 17:00:00 PM, the bell shall ring once every 2 hours for 10 seconds.

Action required:

to realize the above control, the control of 11 time intervals from Mon to Fri and 6 time intervals on Sat and Sun is necessary. In the relay control used in the past, a lot of time-delayed relays are needed and the line connection is quite complicated. Using FAB, all these will become very simple. Please refer to the function diagram for realisation of the control, as shown in the following figure. There is only one line section for its required external connection, which means that you can realise the timing control of the school bell only by connecting one output of FAB directly to the bell. The program diagram is as follows:

FAB Intelligent Control

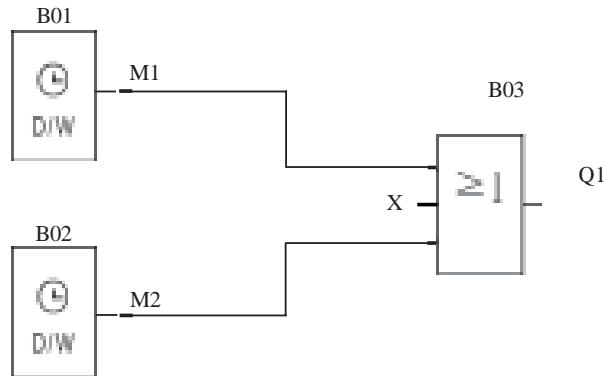

When FAB is used for the above control, it is very simple both in the connection of the external line and in editing the program. When QUICK II programming software is used for editing the control program, it is only necessary to set two time switch blocks.



The set of FB is as follows:

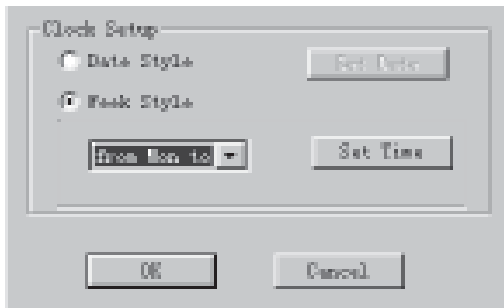

Frequency	State	Time
0	OFF	0-0-0
1	OFF	0-0-10
2	ON	1-0-0
3	OFF	1-0-10
4	ON	2-0-0
5	OFF	2-0-10
6	ON	3-0-0
7	OFF	3-0-10
8	ON	4-0-0
9	OFF	4-0-10
10	ON	5-0-0
11	OFF	5-0-10
12	ON	6-0-0
13	OFF	6-0-10
14	ON	7-0-0
15	OFF	7-0-10
16	ON	8-0-0
17	OFF	8-0-10
18	ON	9-0-0
19	OFF	9-0-10
20	ON	10-0-0
21	OFF	10-0-10



B02



The set of FB is as follows:



Resource	State	Task	Time
0	ON	From Set to Stop	0-0-0
1	OFF	From Set to Stop	0-0-0
2	ON	From Set to Stop	0-0-0
3	OFF	From Set to Stop	0-0-0
4	ON	From Set to Stop	0-0-0
5	OFF	From Set to Stop	0-0-0
6	ON	From Set to Stop	0-0-0
7	OFF	From Set to Stop	0-0-0
8	ON	From Set to Stop	0-0-0
9	OFF	From Set to Stop	0-0-0
10	ON	From Set to Stop	0-0-0
11	OFF	From Set to Stop	0-0-0

8.2 The illumination of multifunction switch in stairs, halls etc.

1. When the light switch has been pressed, the illumination will be connected and then be cut off automatically after the set time of 3 minutes.
2. Lights glimmer for 5 seconds before being switched off.
3. When the switch is pressed again, the illumination will be on as usual.
4. When the switch is pressed for more than 2 seconds the illumination will be on as usual.
5. The illumination will be automatically connected every day at PM6:30 and be cut off every day at AM6:30, the function block program diagram as follows:

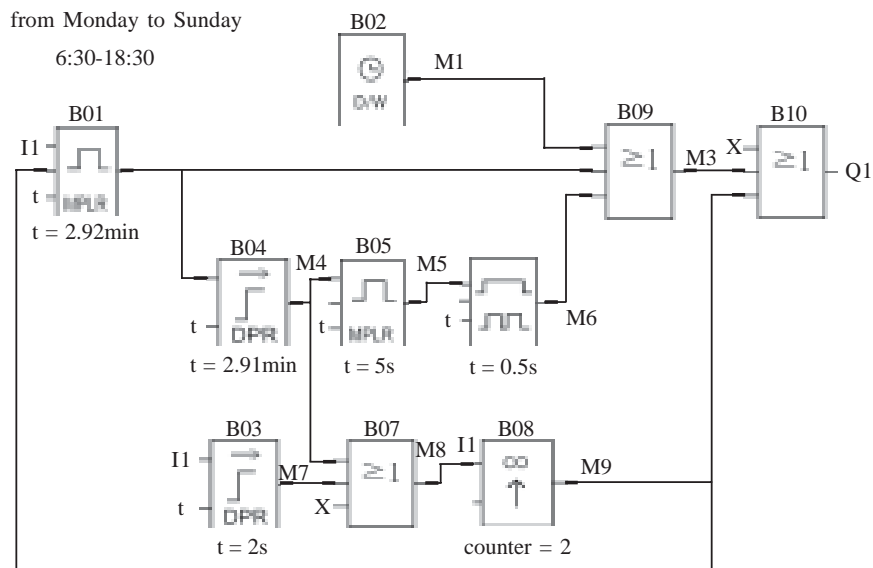



8.3 Automatic gate control requirements:

1. Opening and closing of the gate shall be controlled by the guard in the control room.
2. Normally the gate shall be opened or closed completely, but the opening and closing action can be interrupted at any time.
3. The alarm lamp shall begin to flash when the gate acts and shall keep flashing as long as the gate continues to move.
4. A pressure damper shall be provided so that the gate can be automatically opened when it touches a person or an article.

The Function Block Program Diagram is as follows:

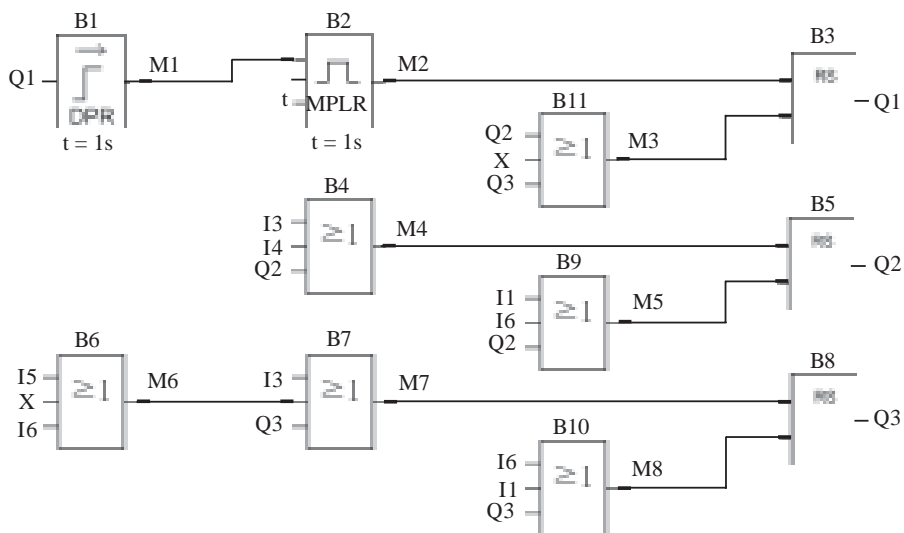

Note:

- Q1 shall be connected to the flashing lamp;*
- Q2 the gate-open motor contactor;*
- Q3 to the gate-close motor contactor;*
- I1 to gate-open switch; I2 to the gate-open switch; I3 to the stop switch; I4 to the gate-open limit switch; I5 to the gate-close limit switch; and I6 to the safety pressure damper.*



8 . 4 Ventilation system

Requirements: The ventilation system shall be able to send fresh air into the room and to exhaust the waste gas out of the room;

1. Waste gas exhaust unit and fresh air forced-draft unit shall be installed in the room.
2. The ventilation system shall be controlled by the control monitor.
3. No over atmospheric pressure is allowed in the room at any time.
4. The fresh air forced-draft unit can not be put into service until the flow monitor indicates that the waste gas exhaust unit is in normal operation.
5. In case of any fault in the ventilation system, the alarm lamp shall be on.

The Function Block Program Diagram is as follows:

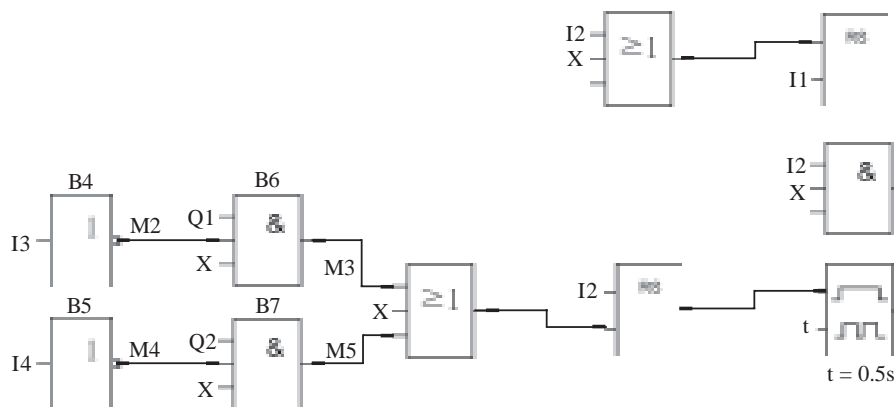

Note:

- Q1 shall be connected to the contactor of waste gas exhaust unit;*
- Q2 to the contactor of the fresh air forced-draft unit;*
- Q3 to the fault alarm lamp;*
- I1 to the activate exhaust switch;*
- I2 to the stop exhaust switch;*
- I3 to the waste gas flow monitor;*
- I4 to the fresh air flow monitor.*



8 . 5 Control requirements for neon lamp control system:

1. Display mode, for example: Array Electronics Welcomes You !

- 1 . 1 Displaying Array
- 1 . 2 Displaying Array Electronics
- 1 . 3 Displaying Welcomes You!"
- 1 . 4 Displaying Array Electronics Welcomes You
- 1 . 5 Displaying Welcomes You!
- 1 . 6 Displaying Array Electronics
- 1 . 7 Cycling 1.1 ~ 1.6

2. Control requirements

1) The neon lamp shall be automatically turned on at 18:00 and off at 24:00 every day.

2) The control can be switched over with the manual/automatic/off selection switch.

Manual: The neon lamp control system can be activated through the manual switch -at any time.

Automatic: The neon lamp control system can be automatically activated when the clock switch or light sensitive switch triggers the output.

Off: The neon lamp system shall be switched off as the manual/automatic/off selection switch is pressed twice and switched on as it is pressed for the third time.

3) The light sensitive switch shall be provided to complement the time switch so that the lamp will be automatically turned on when the light is weak and off when the light is sufficient.

4) Rain detector: On a rainy day, the neon lamp system shall be automatically switched off.

5) Over (under) voltage detector: The system will be automatically switched off when the operating voltage of the neon lamp is too high or too low.

3. Input/output assignment

- I1 rain detector.
- I2 over (under) voltage detector.
- I3 light sensitive switch.
- I4 manual/ automatic/off selection switch.



Q1 to be connected to the enable terminal of Array segment;
 Q2 to the enable terminal of Electronics segment;
 Q3 to the enable terminal of Welcome You! segment.
 Following is the Function Block Program Diagram:

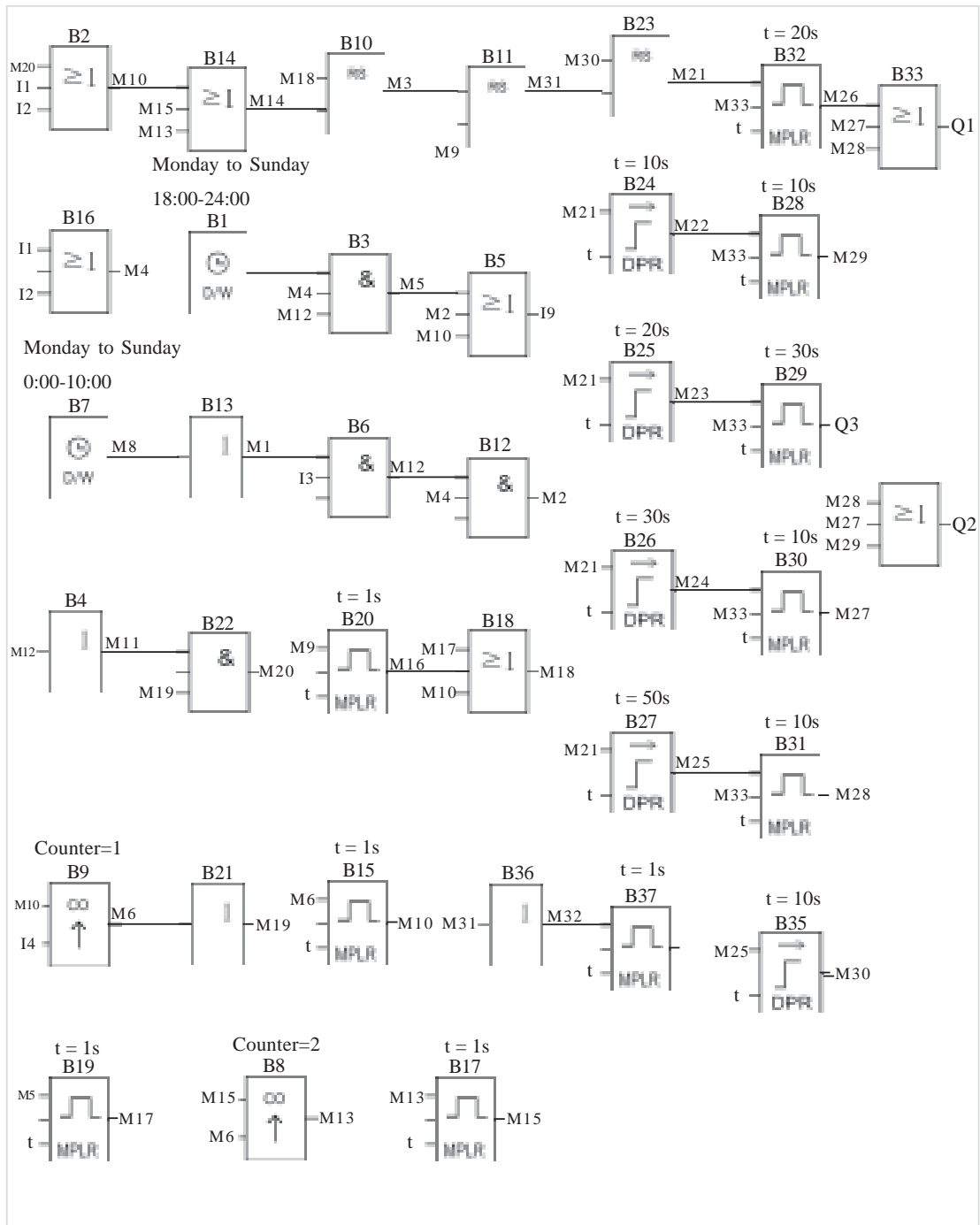



8 . 6 Illumination system for display windows

Control requirements:

1. Basic lighting for the display period:

a) Time:

Monday to Friday 8:00~22:00;

On Saturday 8:00~24:00;

On Sunday 9:00~20:00;

b) Automatic off: the basic lighting can be automatically turned off whilst maintaining minimum illumination and display lighting.

2 . Additional requirements for night lighting :

a) Time:

Monday to Friday light sensitive switch is triggered at 22:00 ;

On Saturday light sensitive switch is triggered at 24:00;

On Sunday light sensitive switch is triggered at 20:00 ;

b) Light sensitive switch triggering/ automatic off: can automatically turn off the minimum illumination and the display lamps when it is on and can also automatically turn on the minimum illumination and display lighting when it is off.

3. Minimum illumination and display lighting in non-display period:

a) The minimum illumination and the display lighting shall be maintained and shall be automatically turned on when the shopping period ends and the basic lighting and night lighting are turned off.

4. Test switch:

All lamp groups can be tested when the test switch is pressed.

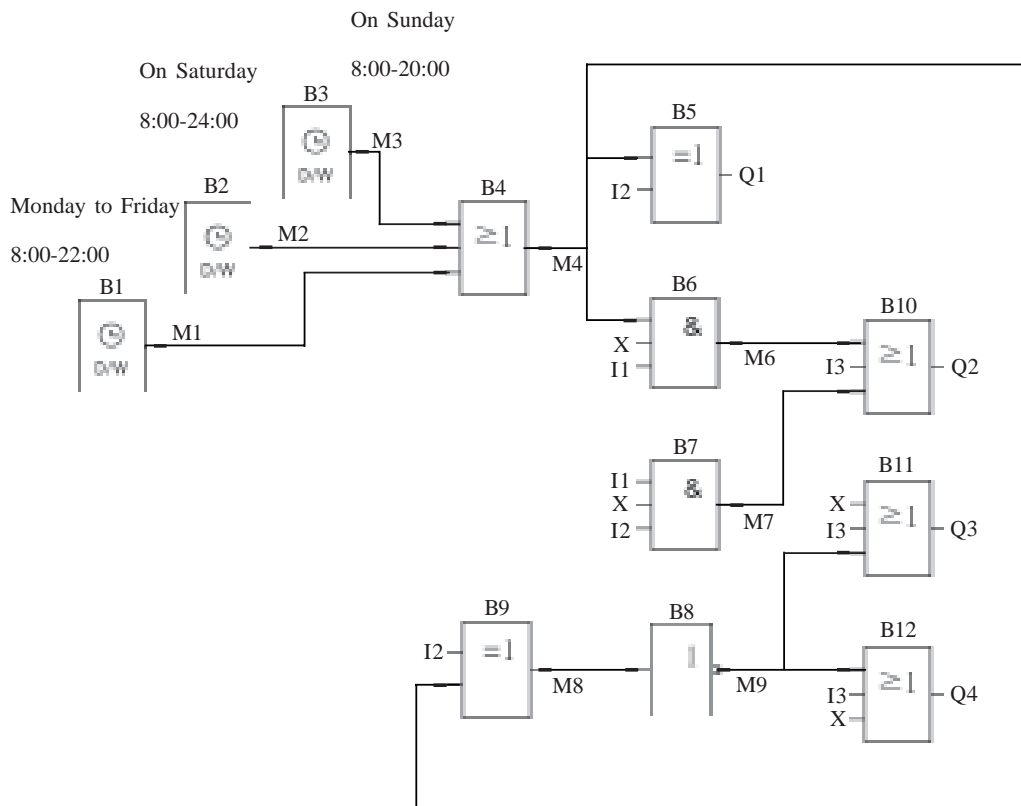

Note:

- I1 shall be connected to the light sensitive switch;*
- I2 to the auto/manual selection switch;*
- I3 to the test switch;*
- Q1 to the basic lighting in display period;*
- Q2 to the night additional lighting within display period;*
- Q3 to the minimum illumination maintaining during non-display period;*
- Q4 to the projection light for special commodities in non-display period.*

8 . 7 Application of FAB in building management

Control requirements:

1. Automatic reading of various meters: the watt-hour meter, water meter and gas meter can be read automatically;



- 2 . Fire protection and anti burglar functions can be realized;
- 3 . Start and stop of relevant electrical appliances can be controlled.

FAB can flexibly satisfy the automatic building control requirements and can realize central monitor and control in sophisticated intelligent living quarter.

1) FAB central control communication connection

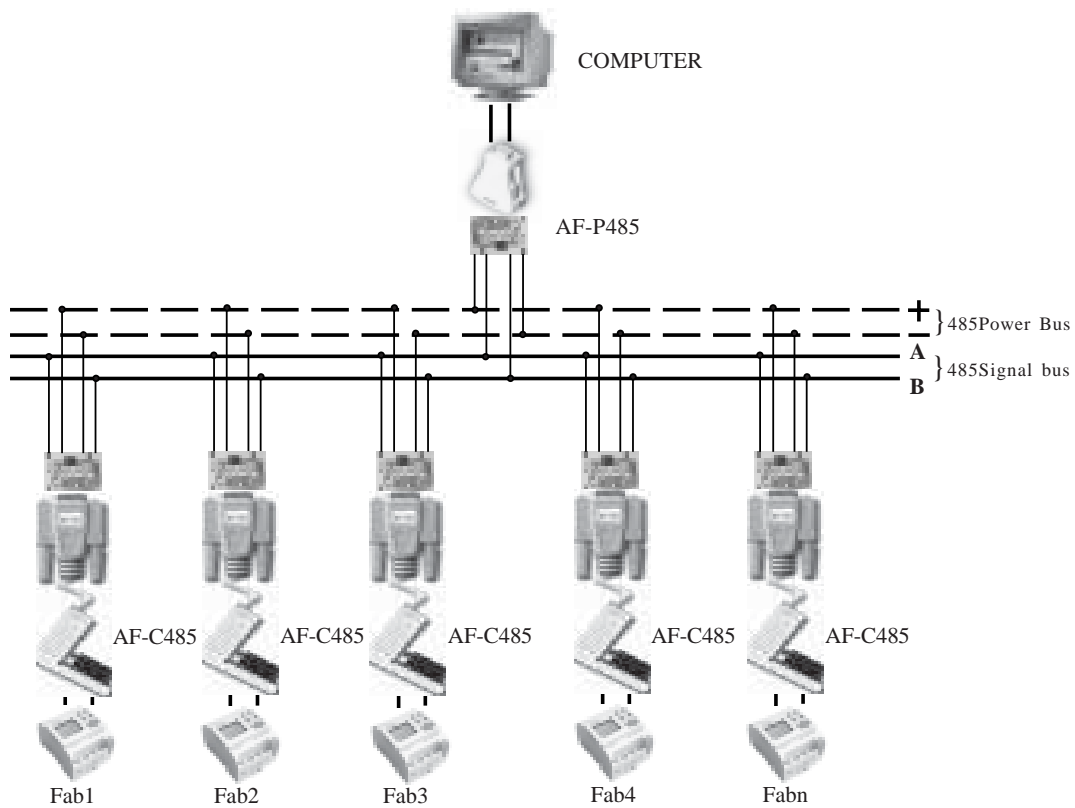

2) Assignment of FAB input/output points.

I1 shall be connected to the temperature sensor and Q0 shall be connected to the air conditioner so that the air conditioner is controlled by the temperature;

I2 shall be connected to the smoke and fire detector for alarm of fire;

I3 shall be connected to the gas detecting sensor,



Q1 shall be connected to the ventilation equipment and Q2 shall be connected to the alarm so that the ventilation equipment is controlled by the air status; I4 shall be connected to the door/window sensor activating the alarm I5 shall be connected to the water meter, while I6 shall be connected to the watthour meter.

8.8 Application of FAB in a voltage diode counting and packing assembly line

The PC Assembly Line Central Control System Diagram is as follows:

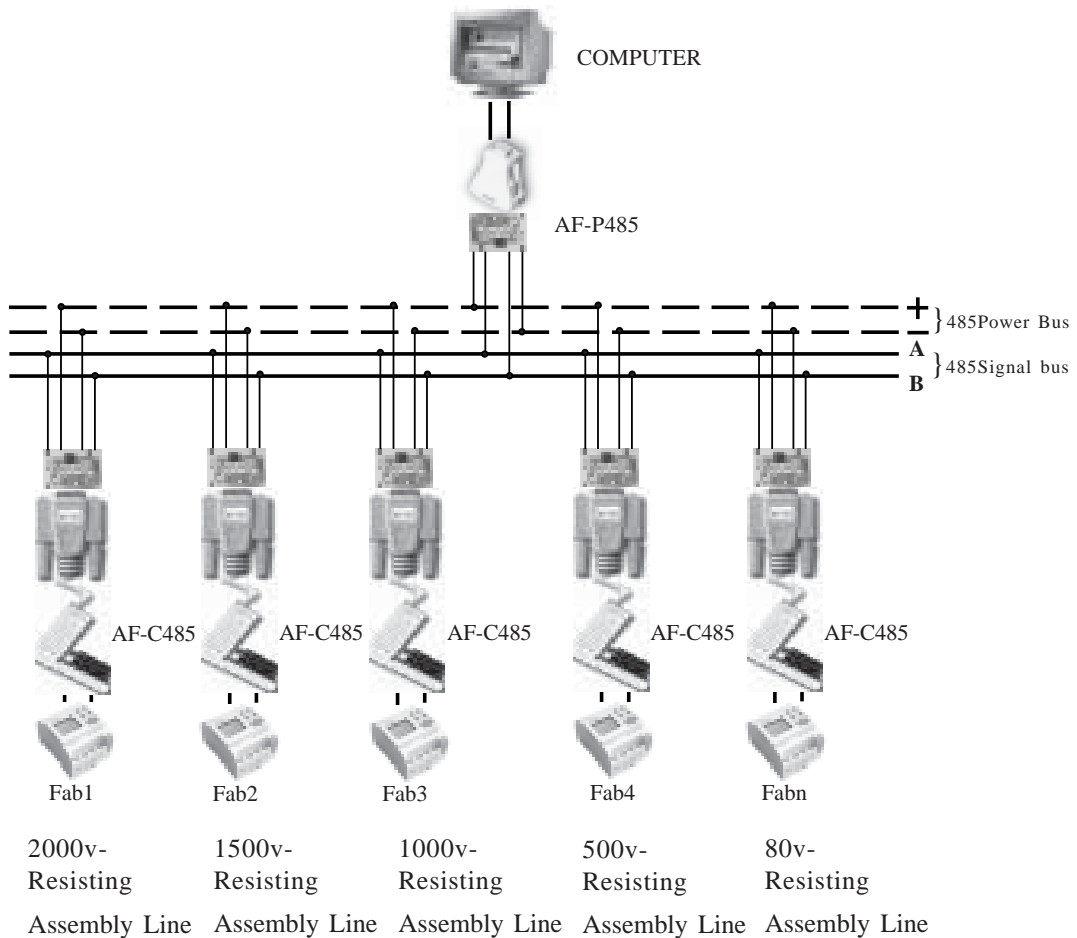



Control requirements and configuration:

1. Control of 2000V withstand voltage counting flow line, to be completed by FAB1

1) I5 is used for counting the diodes entering the flow line (automatically giving the sum of the diodes to be tested);

2) I6 is used for counting of diodes with 2000V withstand voltage;

3) Q1 is used for labeling of diodes with acceptable withstand voltage;

4) Q2 is used for enclosing of diodes already labeled;

5) If the counting value of I6 is multiples of 1000, Q3 will be switched on to start the packing equipment;

6) Diodes that can not withstand 2000V voltage shall be transferred to 1500V flow line.

2. Control shall be completed by FAB2 for 1500V withstand voltage flow line, by FAB3 for 1000V withstand voltage flow line, by FAB4 for 500V withstand voltage flow line and by FAB5 for 80V withstand voltage flow line. The control requirements and configuration are the same as mentioned above.

3. Monitoring of all FABis can be realized by installation of monitoring software FAB-SCADA on PC. Each FAB answers through bus 485 the instructions from PC, including diode counting and input/output (I/O) status of FAB; PC will display each acquired FAB data on the screen and can provide data storage and inquiry functions, to allow prompt analysis of the counting of different withstand voltage diodes.





Chapter VIII Quality Guarantee

Quality Guarantee The product has been strictly tested for quality before delivery from our plant and it complies with (as appropriate) all product requirements listed in this manual. When properly installed it will work in accordance with its' specifications.

Warranty Period This product is warranted against defects in material and manufacturing for a period of one year from the date of delivery. During the warranty period, ARRAY shall be responsible for necessary repairs or replacement, as long as the product is proven to be inherently defective.

Warranty Range During the above mentioned Warranty Period, if the product is fails to perform in accordance with its' specifications and has not been misused it shall be delivered to a service centre, which ARRAY authorizes, for free repair. ARRAY reserves the right to repair or replace the product in accordance with it's discretion. In the event of product replacement the buyer will be informed and shall be responsible for reloading software, unless agreed otherwise. The buyer shall pay the shipping charge for delivery to the ARRAY service centre and the ARRAY service centre will repair or replace the product and deliver it to the buyer free of charge.

The above warranty does not include the following circumstances.

1. Improper installation testing or operation
2. Misuse
3. Damage caused by unauthorized dismantling of the product
4. Damage to consumable parts such as rubber cover, buttons, batteries, relays etc.

